

MPRI

# Reduction of models of intra-cellular signalling pathways

Jérôme Feret

DI - ÉNS

*inria*  
informatics mathematics



PSL  
RESEARCH  
UNIVERSITY

<http://www.di.ens.fr/~feret>

Wednesday, the 6th of November, 2018

# On the menu today

1. Context and motivations
2. Case studies
3. Reduction of ordinary differential equations
4. Abstraction of the information flow
5. Model reduction
6. Conclusion

# Intra-cellular signalling pathways

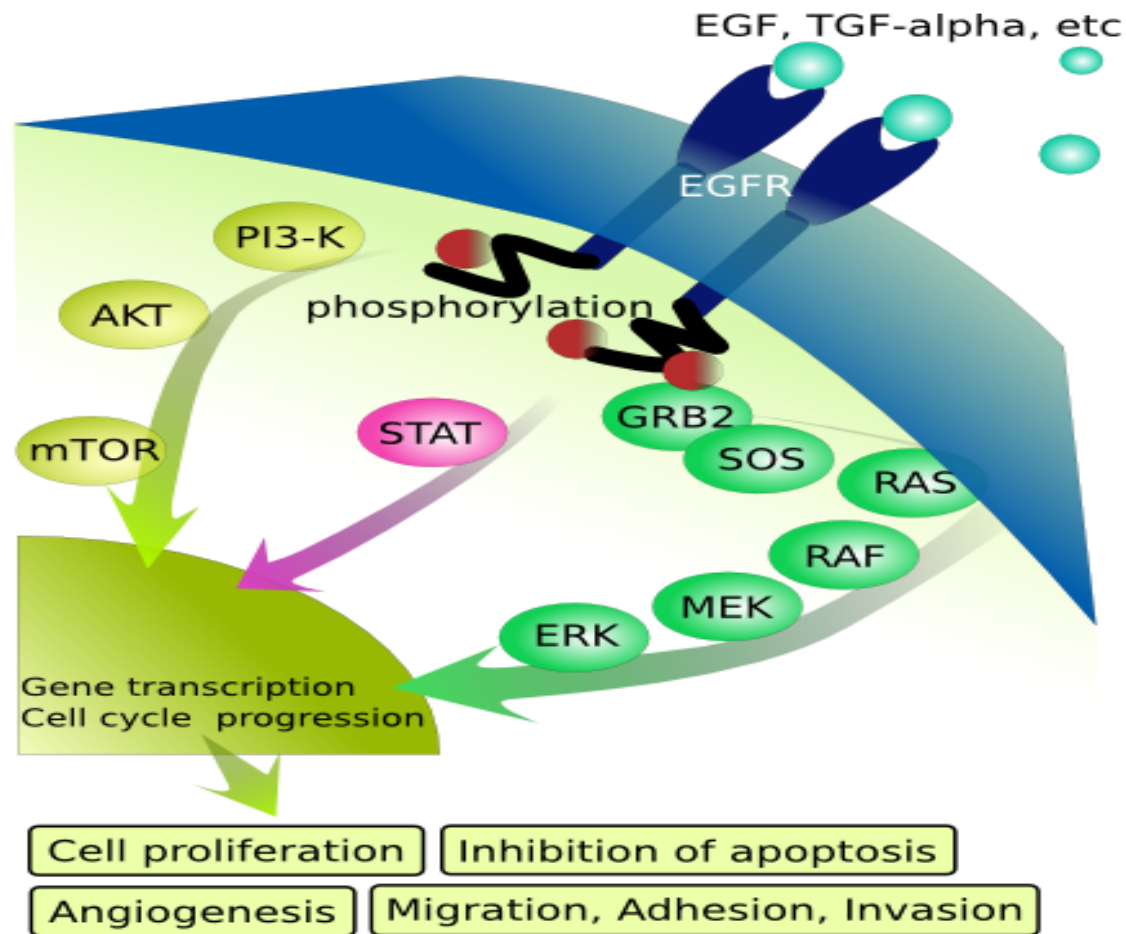

Eikuch, 2007

# Interaction maps

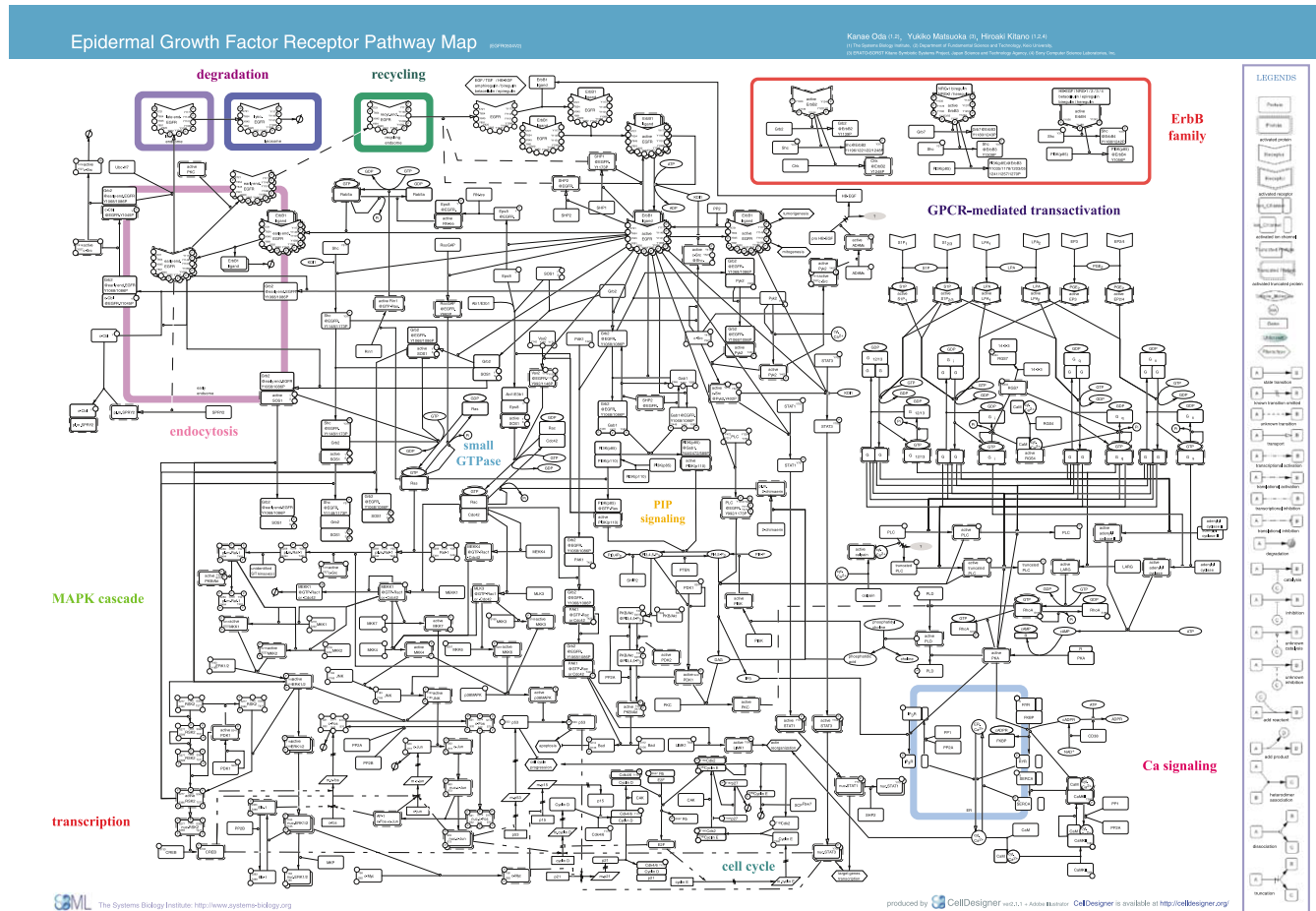

Oda et al, 2005

# Models of the behaviour of the system

$$\left\{ \begin{array}{l} \frac{dx_1}{dt} = -k_1 \cdot x_1 \cdot x_2 + k_{-1} \cdot x_3 \\ \frac{dx_2}{dt} = -k_1 \cdot x_1 \cdot x_2 + k_{-1} \cdot x_3 \\ \frac{dx_3}{dt} = k_1 \cdot x_1 \cdot x_2 - k_{-1} \cdot x_3 + 2 \cdot k_2 \cdot x_3 \cdot x_3 - k_{-2} \cdot x_4 \\ \frac{dx_4}{dt} = k_2 \cdot x_3^2 - k_2 \cdot x_4 + \frac{v_4 \cdot x_5}{p_4 + x_5} - k_3 \cdot x_4 - k_{-3} \cdot x_5 \\ \frac{dx_5}{dt} = \dots \\ \vdots \\ \frac{dx_n}{dt} = -k_1 \cdot x_1 \cdot c_2 + k_{-1} \cdot x_3 \end{array} \right.$$

# Bridge the gap between...

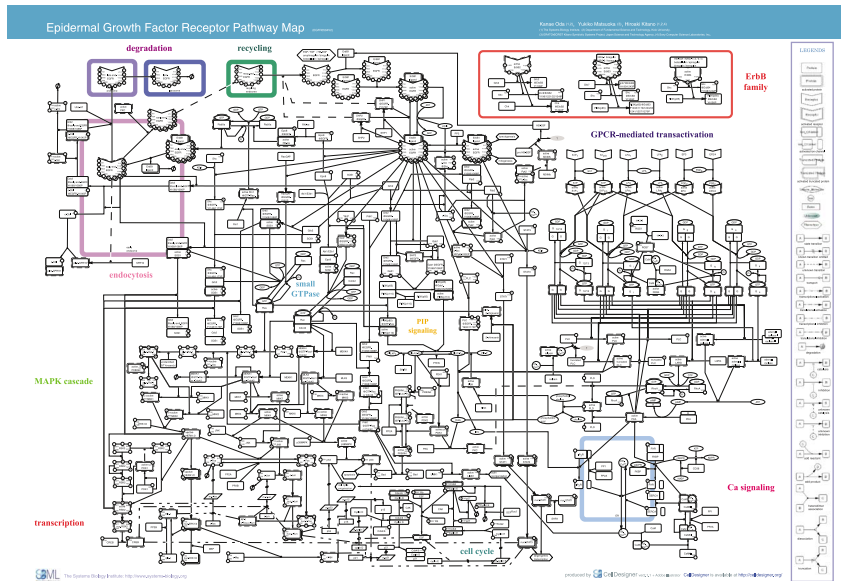

$$\left\{ \begin{array}{l} \frac{dx_1}{dt} = -k_1 \cdot x_1 \cdot x_2 + k_{-1} \cdot x_3 \\ \frac{dx_2}{dt} = -k_1 \cdot x_1 \cdot x_2 + k_{-1} \cdot x_3 \\ \frac{dx_3}{dt} = k_1 \cdot x_1 \cdot x_2 - k_{-1} \cdot x_3 + 2 \cdot k_2 \cdot x_3 \cdot x_3 - k_{-2} \cdot x_4 \\ \frac{dx_4}{dt} = k_2 \cdot x_3^2 - k_2 \cdot x_4 + \frac{v_4 \cdot x_5}{p_4 + x_5} - k_3 \cdot x_4 - k_{-3} \cdot x_5 \\ \frac{dx_5}{dt} = \dots \\ \vdots \\ \frac{dx_n}{dt} = -k_1 \cdot x_1 \cdot c_2 + k_{-1} \cdot x_3 \end{array} \right.$$

knowledge  
representation

and models of the  
behaviour of systems

# Site-graphs rewriting

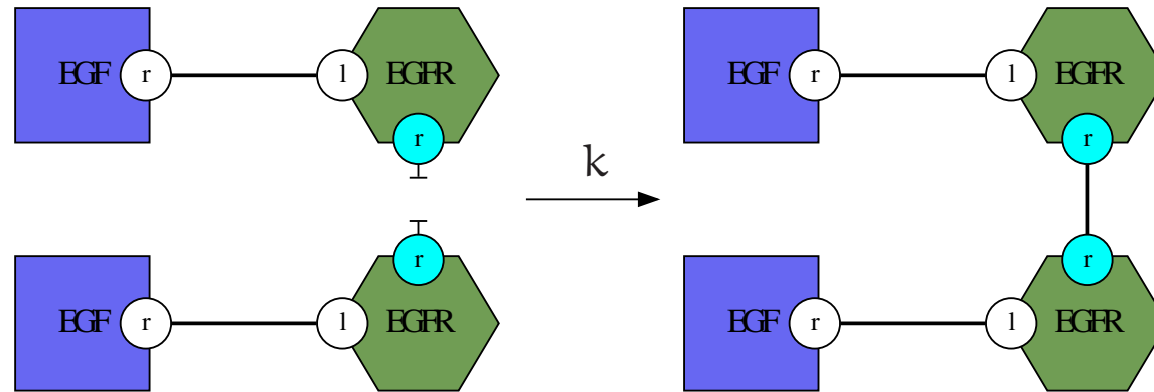

- a language close to knowledge representation;
- rules are easy to update;
- a compact description of models.

# Choices of semantics

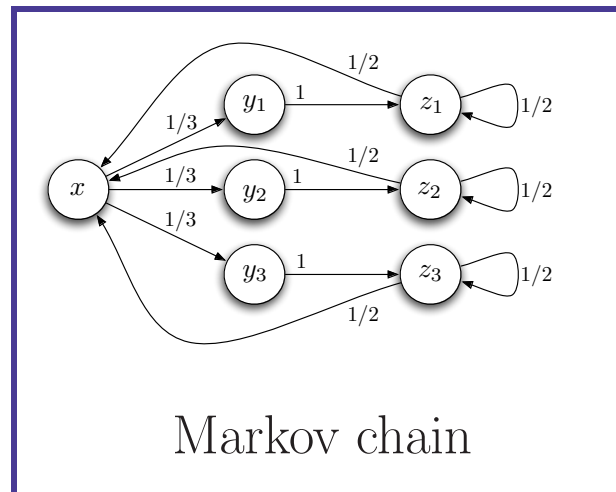
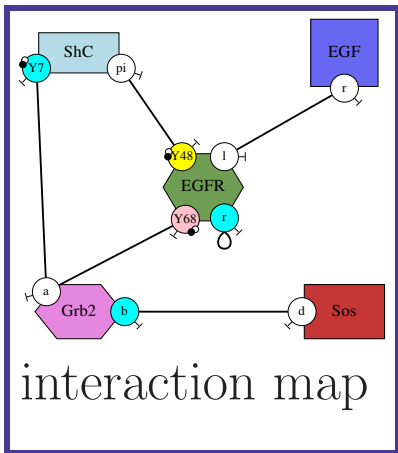
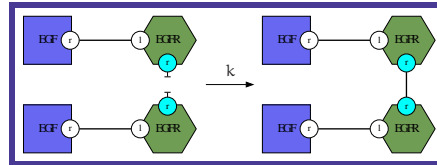

$$\begin{cases} \frac{dx_1}{dt} = -k_1 \cdot x_1 \cdot x_2 + k_{-1} \cdot x_3 \\ \frac{dx_2}{dt} = -k_1 \cdot x_1 \cdot x_2 + k_{-1} \cdot x_3 \\ \frac{dx_3}{dt} = k_1 \cdot x_1 \cdot x_2 - k_{-1} \cdot x_3 + 2 \cdot k_2 \cdot x_3 \cdot x_3 - k_{-2} \cdot x_4 \\ \frac{dx_4}{dt} = k_2 \cdot x_3^2 - k_2 \cdot x_4 + \frac{v_4 \cdot x_5}{p_4 + x_5} - k_3 \cdot x_4 - k_{-3} \cdot x_5 \\ \frac{dx_5}{dt} = \dots \\ \vdots \\ \frac{dx_n}{dt} = -k_1 \cdot x_1 \cdot c_2 + k_{-1} \cdot x_3 \end{cases}$$

ordinary differential equations



# Abstractions offer different perspectives on models

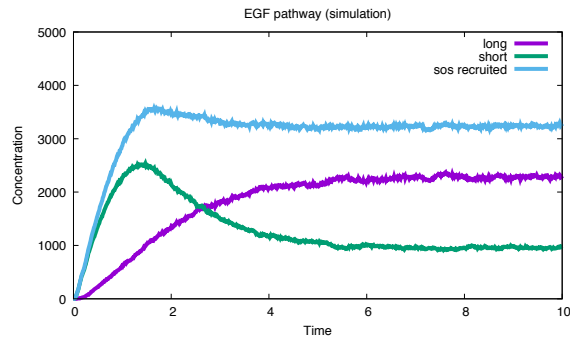

concrete semantics

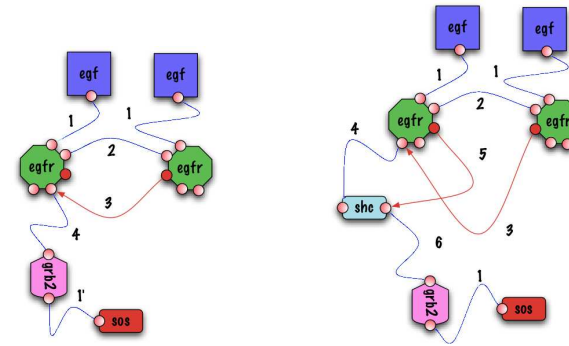

causal traces

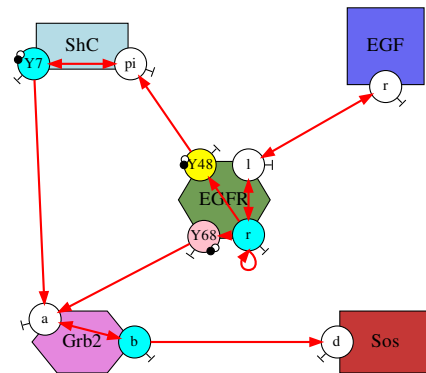

information flow

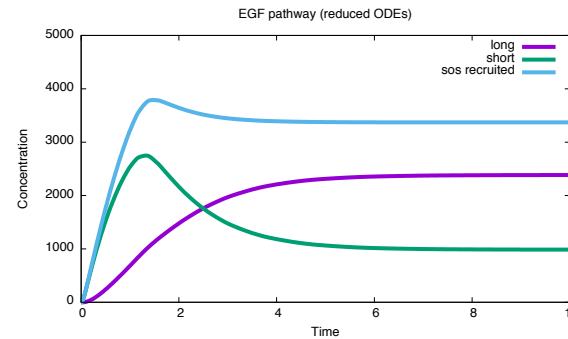

exact projection of the ODE semantics

# Contact map

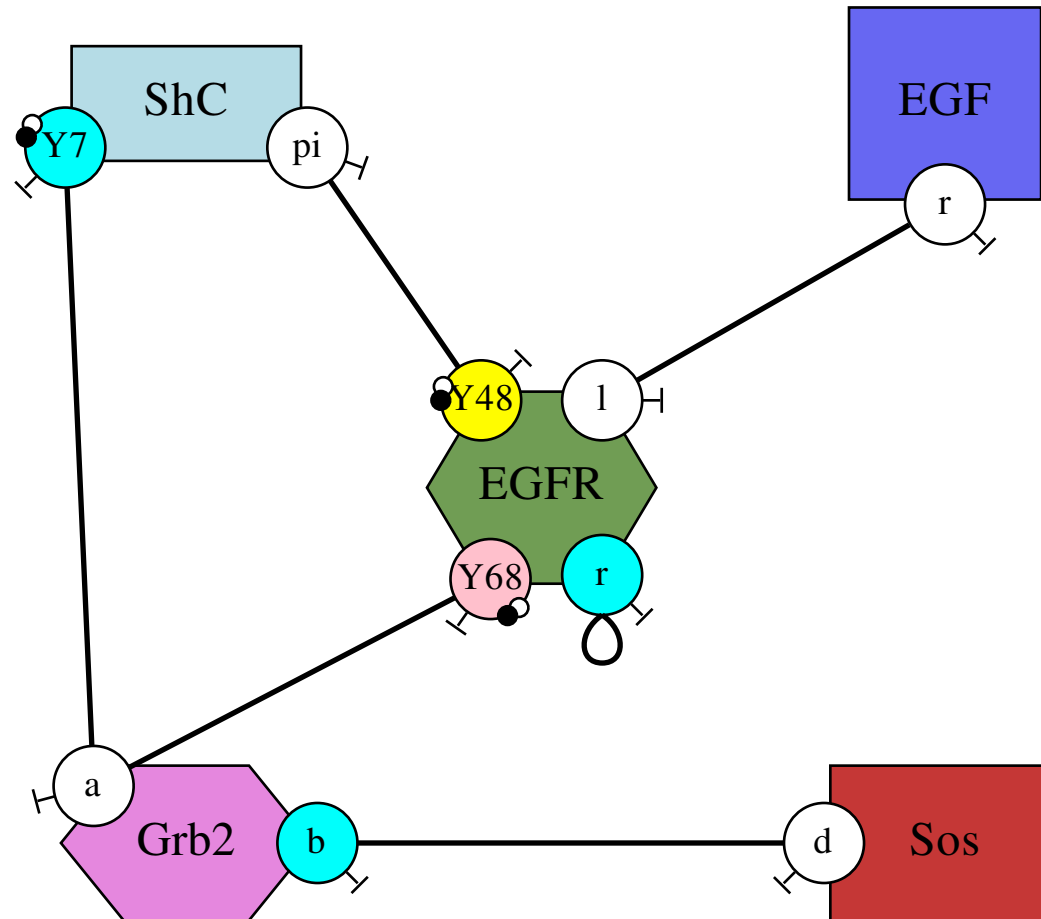

# Causal traces

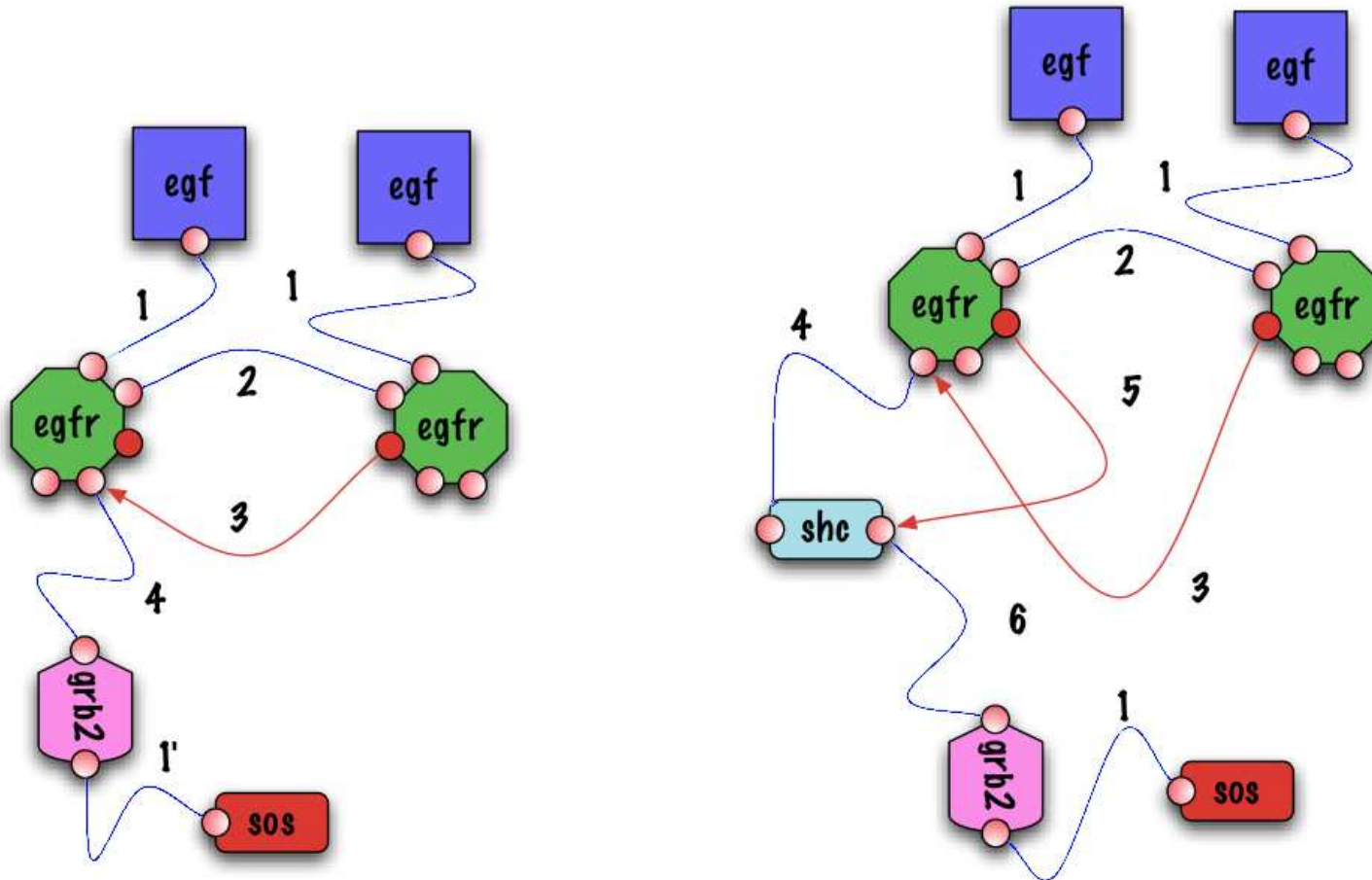

# ODE semantics

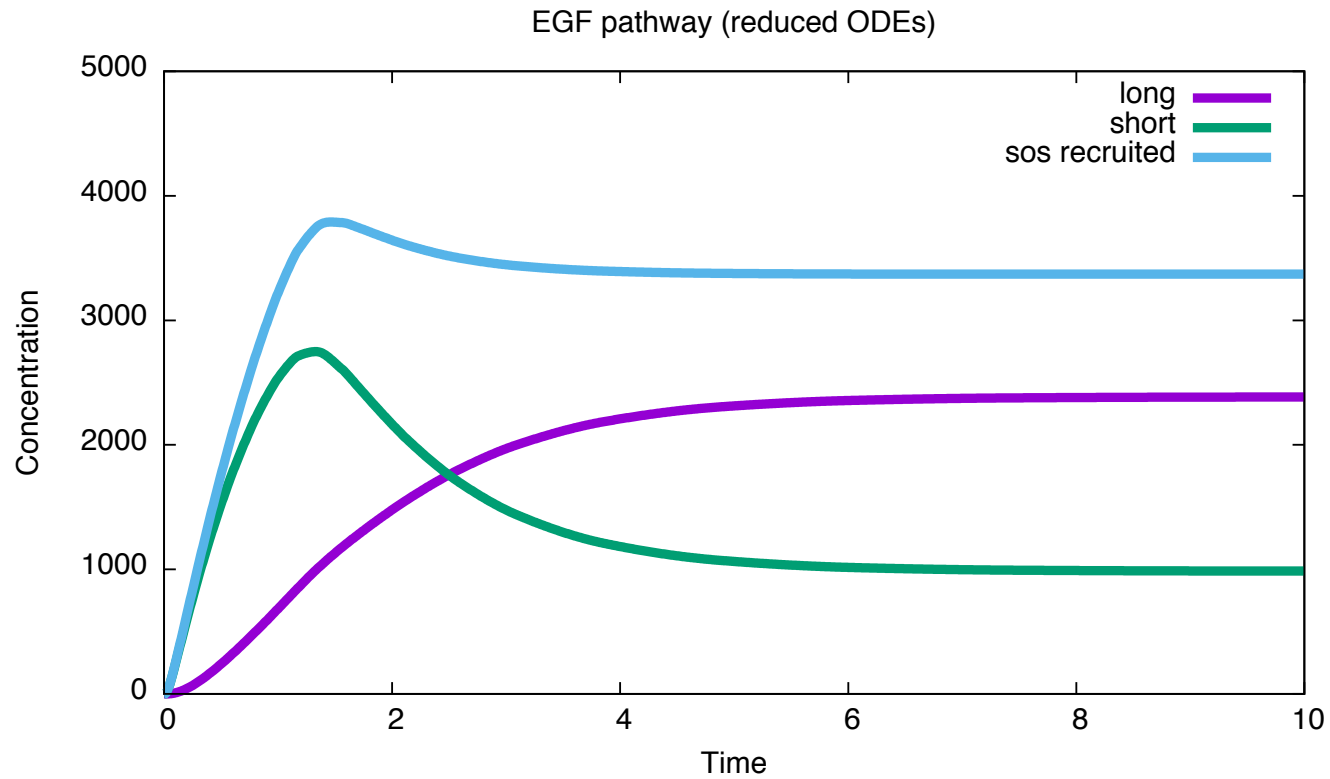

# Causal traces

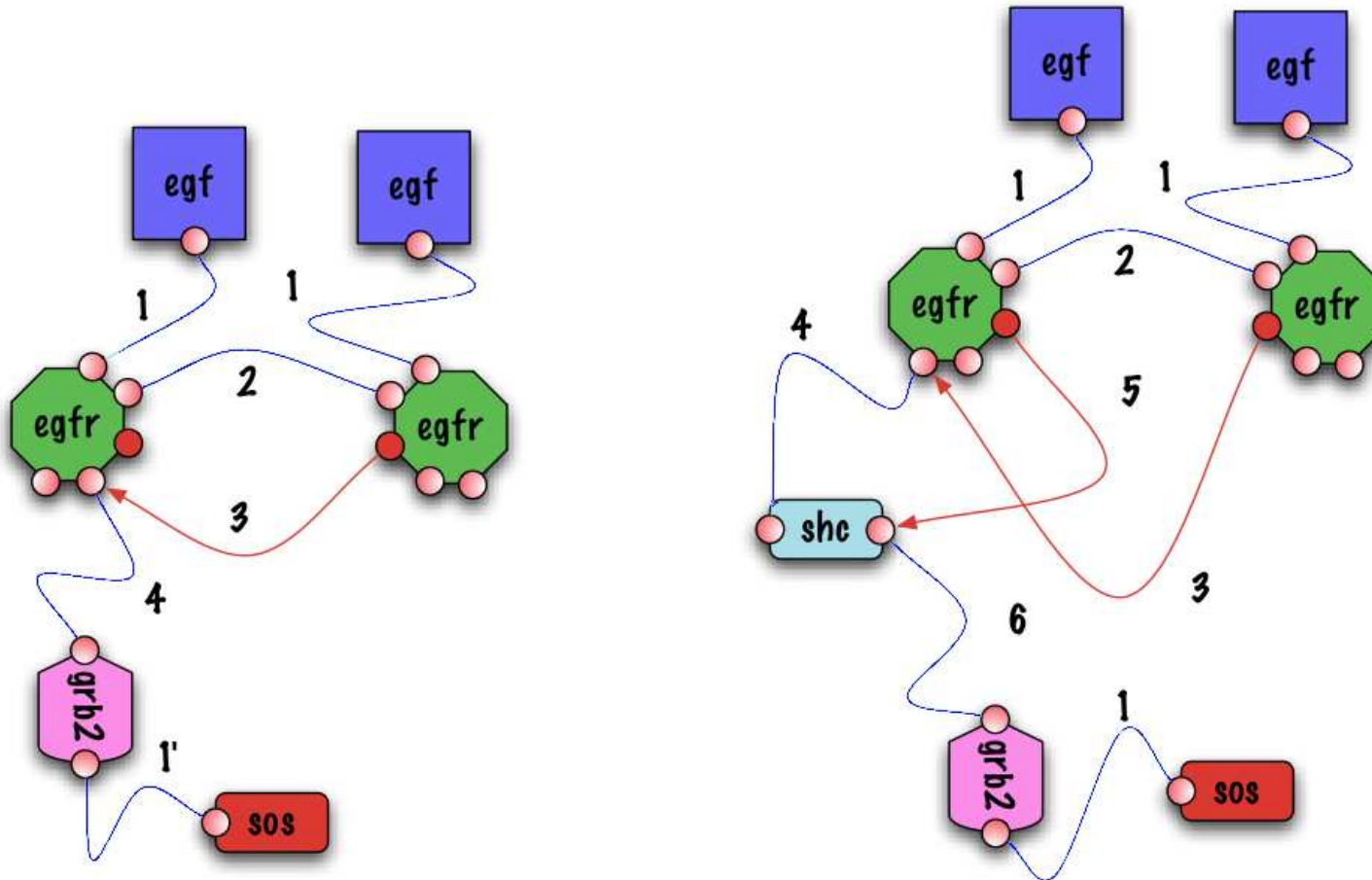

# Combinatorial wall

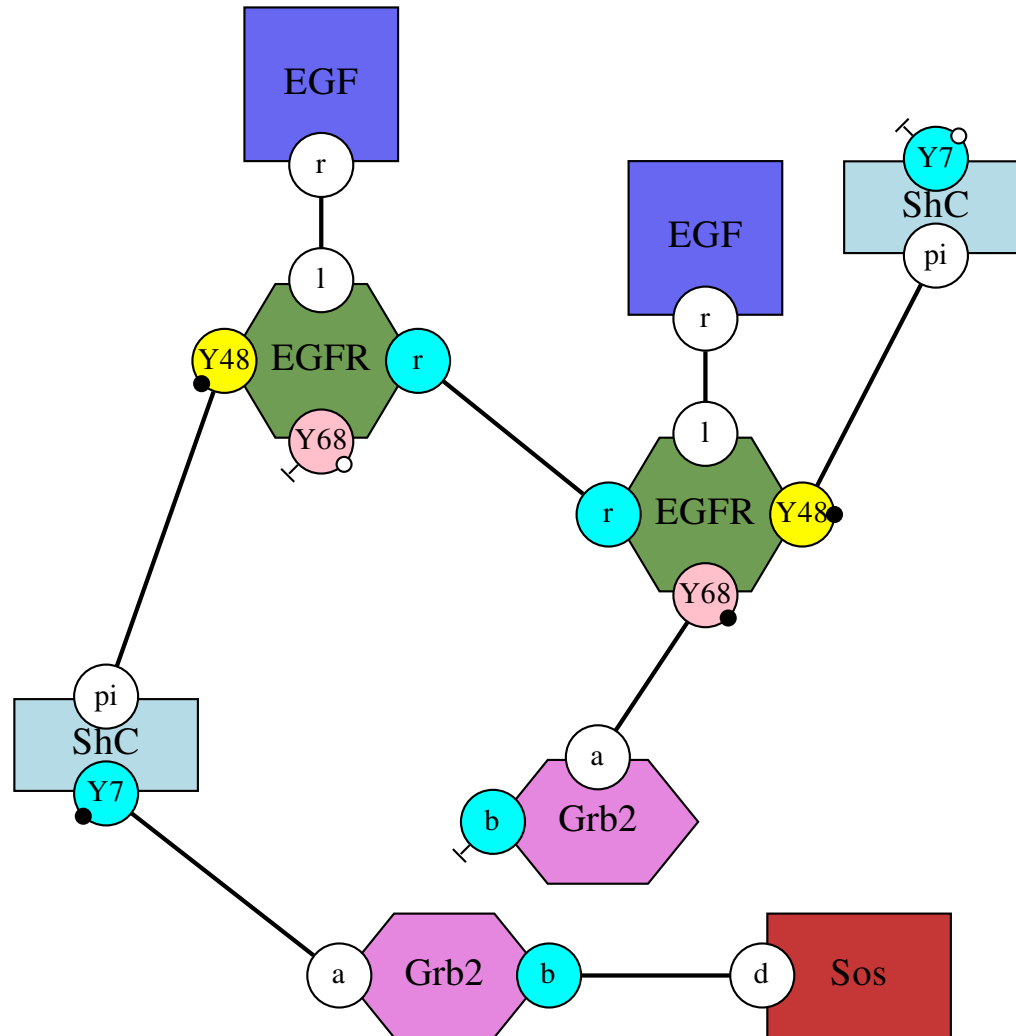



# A potential breach

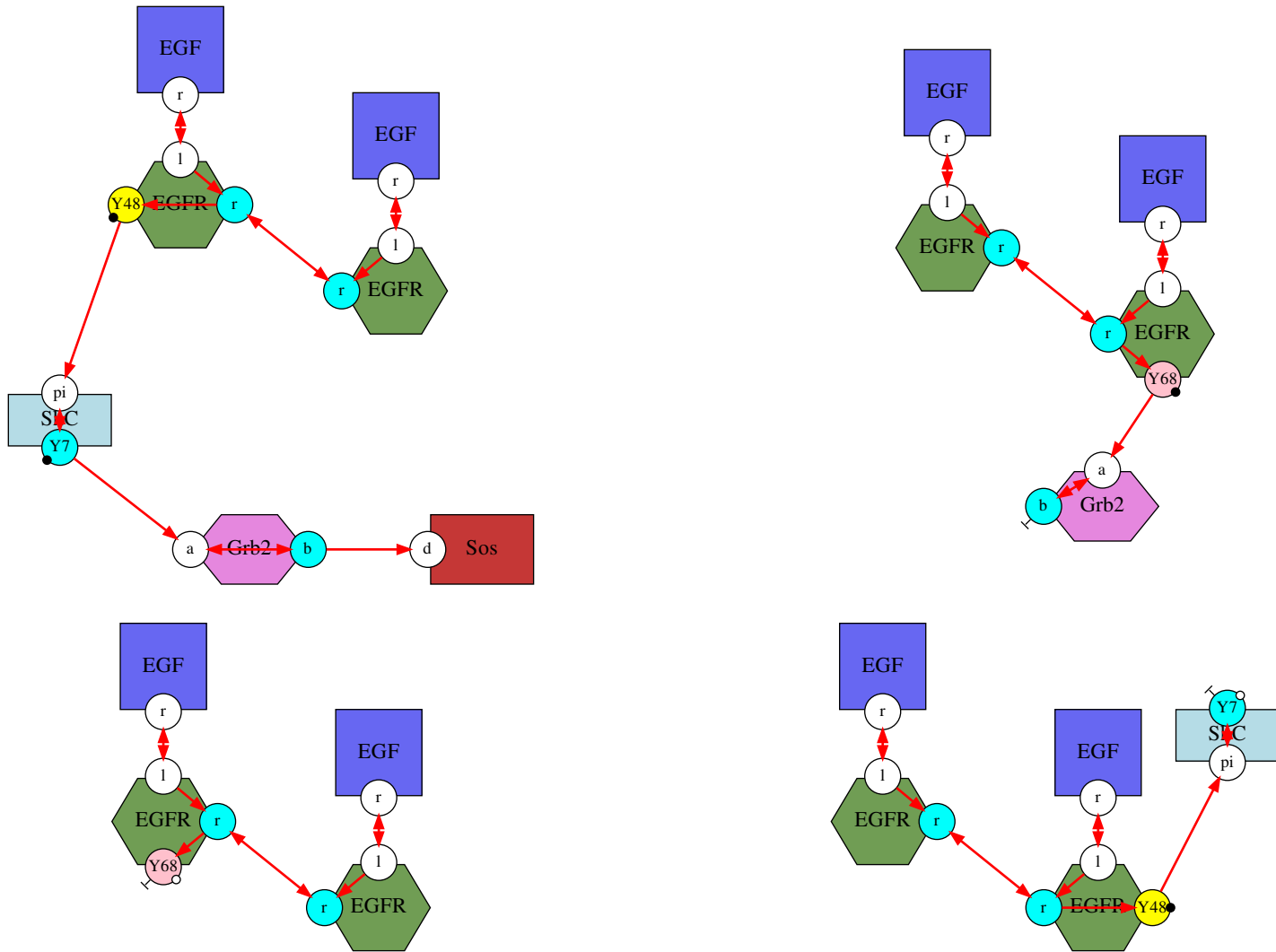



# A potential breach

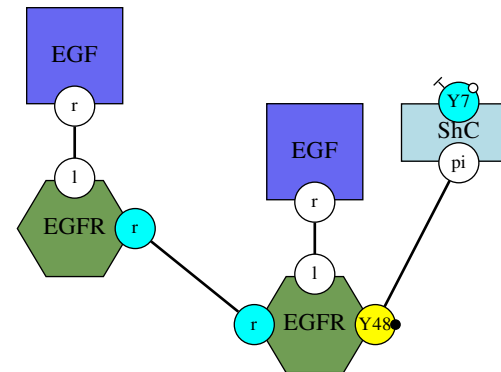
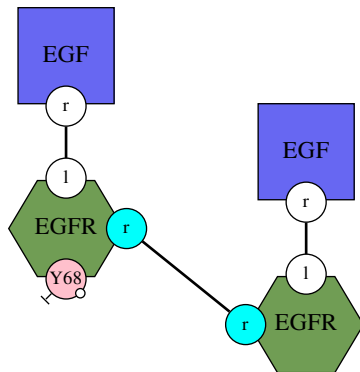
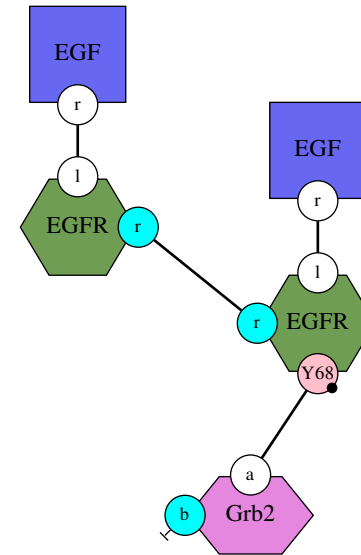
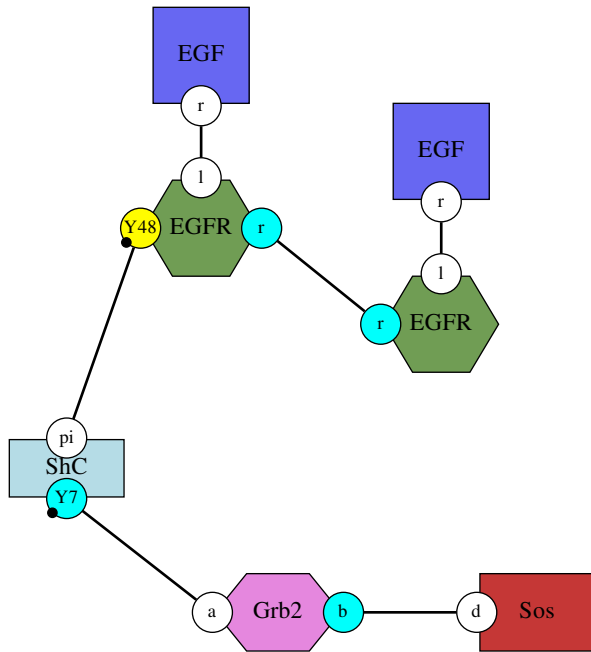

# On the menu today

1. Context and motivations
2. Case studies
3. Reduction of ordinary differential equations
4. Abstraction of the information flow
5. Model reduction
6. Conclusion

# Case study

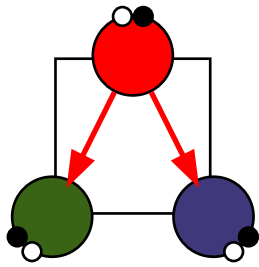

# Case study

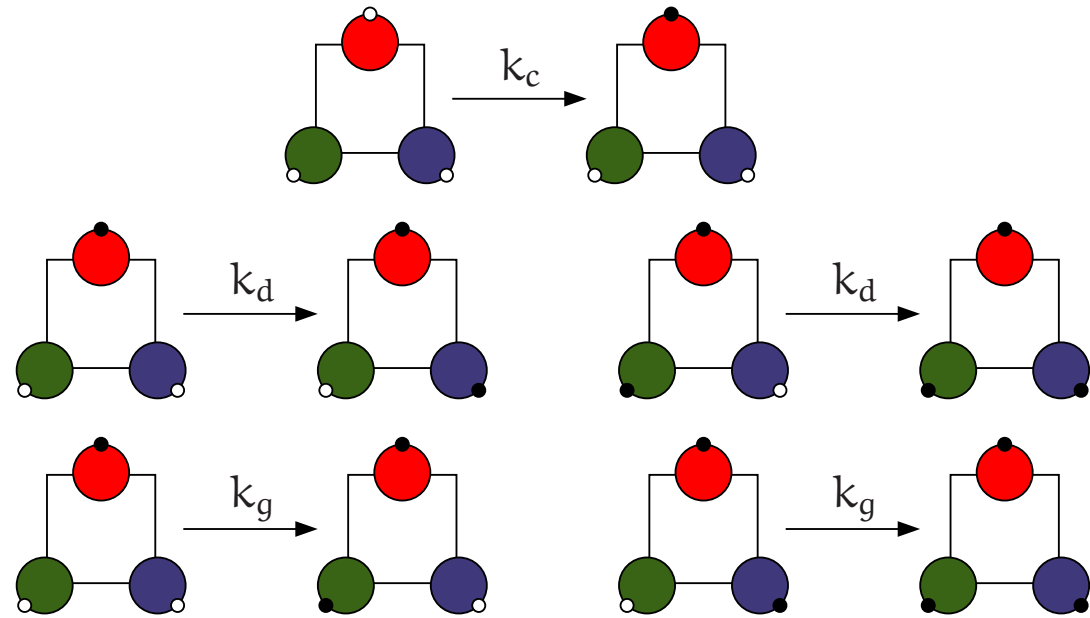
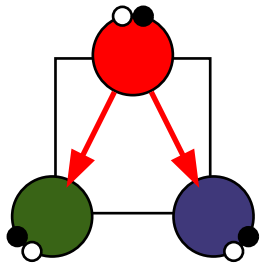

# Law of mass action

We consider that chemical species are elementary particles without any volume, and that they are diffusing in an infinite, perfectly fluid and homogeneous medium without borders.

Let  $\mathcal{X}$  be a set of chemical species.

A reaction network is a set of reactions  $\mathcal{R}$ .

Each reaction  $r$  is defined by:

1.  $\alpha_r$ , a function from  $\mathcal{X}$  to  $\mathbb{N}$  (the reactants);
2.  $\beta_r$ , a function from  $\mathcal{X}$  to  $\mathbb{N}$  (the products);
3.  $k_r$ , a non negative real number (the kinetic rate).

With these notations, the law of mass action defines the behaviour of the concentration  $[X]$  of each chemical species  $X$ :

$$\frac{d[X]}{dt} = \sum_{r \in \mathcal{R}} k_r \cdot (\beta_r(X) - \alpha_r(X)) \cdot \prod_{X' \in \mathcal{X}} [X']^{\alpha_r(X')}.$$

# Case study

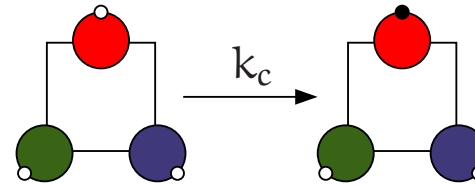
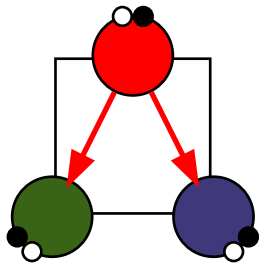

$$\left\{ \begin{array}{l} \frac{d[(u,u,u)]}{dt} = -k_c \cdot [(u,u,u)] \\ \frac{d[(u,p,u)]}{dt} = k_c \cdot [(u,u,u)] \end{array} \right.$$

# Case study

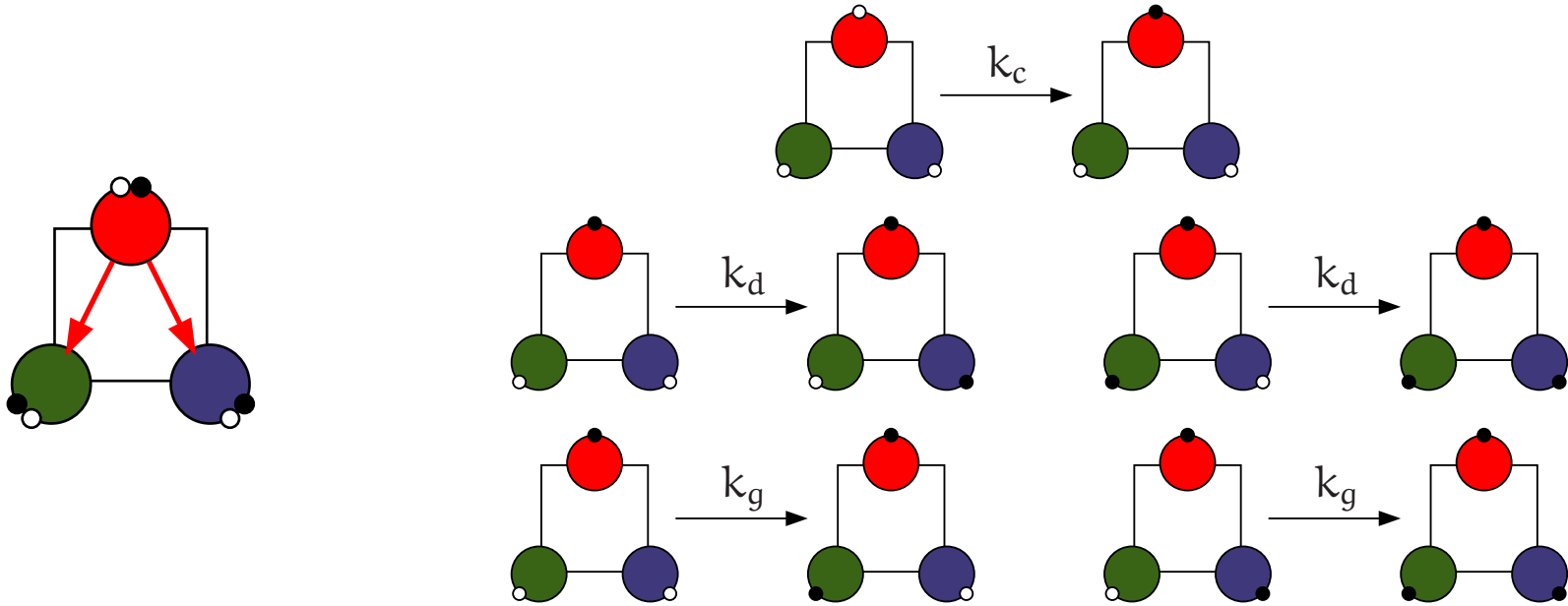

$$\left\{ \begin{array}{l} \frac{d[(u,u,u)]}{dt} = -k_c \cdot [(u,u,u)] \\ \frac{d[(u,p,u)]}{dt} = -k_g \cdot [(u,p,u)] + k_c \cdot [(u,u,u)] - k_d \cdot [(u,p,u)] \\ \frac{d[(u,p,p)]}{dt} = -k_g \cdot [(u,p,p)] + k_d \cdot [(u,p,u)] \\ \frac{d[(p,p,u)]}{dt} = k_g \cdot [(u,p,u)] - k_d \cdot [(p,p,u)] \\ \frac{d[(p,p,p)]}{dt} = k_g \cdot [(u,p,p)] + k_d \cdot [(p,p,u)] \end{array} \right.$$

# Case study

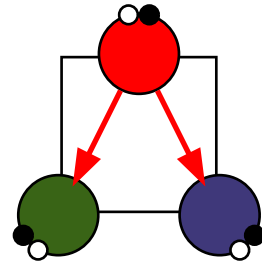



# Case study

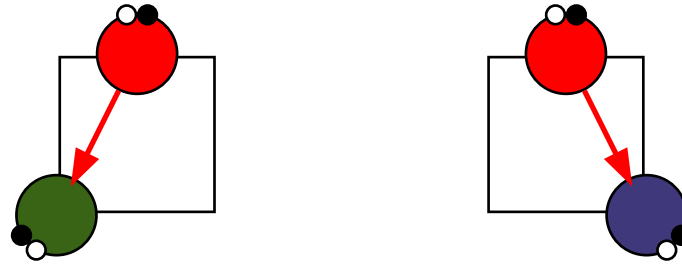

# Case study

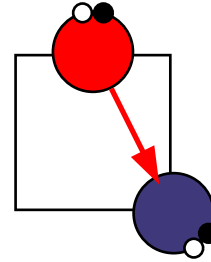
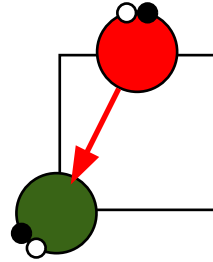

$$[(u, u, u)] = [(u, u, u)]$$

$$[(u, p, ?)] \triangleq [(u, p, u)] + [(u, p, p)]$$

$$[(p, p, ?)] \triangleq [(p, p, u)] + [(p, p, p)]$$

$$\begin{cases} \frac{d[(u, u, u)]}{dt} = -k_c \cdot [(u, u, u)] \\ \frac{d[(u, p, ?)]}{dt} = -k_g \cdot [(u, p, ?)] + k_c \cdot [(u, u, u)] \\ \frac{d[(p, p, ?)]}{dt} = k_g \cdot [(u, p, ?)] \end{cases}$$

$$[(u, u, u)] = [(u, u, u)]$$

$$[(?, p, u)] \triangleq [(u, p, u)] + [(p, p, u)]$$

$$[(?, p, p)] \triangleq [(u, p, p)] + [(p, p, p)]$$

$$\begin{cases} \frac{d[(u, u, u)]}{dt} = -k_c \cdot [(u, u, u)] \\ \frac{d[(?, p, u)]}{dt} = -k_d \cdot [(?, p, u)] + k_c \cdot [(u, u, u)] \\ \frac{d[(?, p, p)]}{dt} = k_d \cdot [(?, p, u)] \end{cases}$$

# What we have learned so far:

We can use the absence of information flow to detect useless correlations between the states of sites in chemical species. We can use this to cut chemical species into fragments.

This transformation loses some information: we cannot compute the concentration of each chemical species anymore.

# A model with symmetries

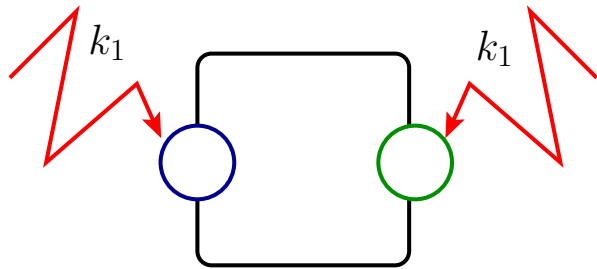

$$\begin{array}{l}
 P \longrightarrow {}^*P \quad k_1 \\
 P \longrightarrow P^* \quad k_1
 \end{array}$$

$$\begin{array}{l}
 P^* \longrightarrow {}^*P^* \quad k_1 \\
 {}^*P \longrightarrow {}^*P^* \quad k_1
 \end{array}$$

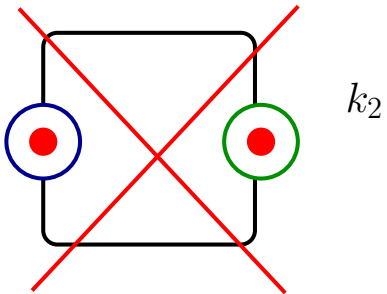

$${}^*P^* \longrightarrow \emptyset \quad k_2$$

# Reduced model

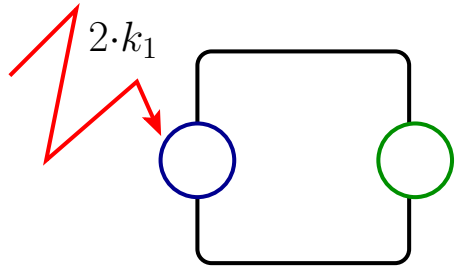

$$P \longrightarrow {}^*P \quad 2 \cdot k_1$$

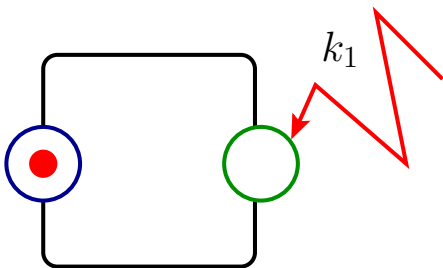

$${}^*P \longrightarrow {}^*P^* \quad k_1$$

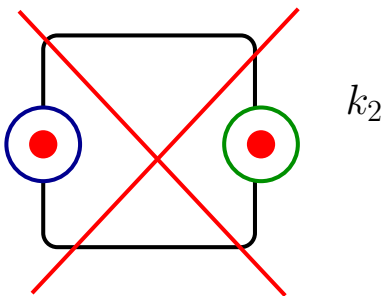

$${}^*P^* \longrightarrow \emptyset \quad k_2$$

# Differential equations

- Initial system:

$$\frac{d}{dt} \begin{bmatrix} P \\ *P \\ P^* \\ *P^* \end{bmatrix} = \begin{bmatrix} -2 \cdot k_1 & 0 & 0 & 0 \\ k_1 & -k_1 & 0 & 0 \\ k_1 & 0 & -k_1 & 0 \\ 0 & k_1 & k_1 & -k_2 \end{bmatrix} \cdot \begin{bmatrix} P \\ *P \\ P^* \\ *P^* \end{bmatrix}$$

- Reduced system:

$$\frac{d}{dt} \begin{bmatrix} P \\ *P + P^* \\ 0 \\ *P^* \end{bmatrix} = \begin{bmatrix} -2 \cdot k_1 & 0 & 0 & 0 \\ 2 \cdot k_1 & -k_1 & 0 & 0 \\ 0 & 0 & 0 & 0 \\ 0 & k_1 & 0 & -k_2 \end{bmatrix} \cdot \begin{bmatrix} P \\ *P + P^* \\ 0 \\ *P^* \end{bmatrix}$$

# Invariant

We wonder whether or not:

$$[{}^*P] = [P^*],$$

Thus we define the difference  $X$  as follows:

$$X \triangleq [{}^*P] - [P^*].$$

We have:

$$\frac{dX}{dt} = -k_1 \cdot X.$$

So the property ( $X = 0$ ) is an invariant.

Thus, if  $[{}^*P] = [P^*]$  at time  $t = 0$ , then  $[{}^*P] = [P^*]$  forever.

# Conclusion

We can abstract away the distinction between chemical species which are equivalent up to symmetries (with respect to the reactions).

1. If the symmetries are satisfied in the initial state:
  - + the abstraction is invertible:
    - we can recover the concentration of any species,  
(thanks to the invariants).
2. Otherwise:
  - some information is abstracted away:
    - we cannot recover the concentration of any species;
  - + the system converges to a state which satisfies the symmetries.



# On the menu today

1. Context and motivations
2. Case studies
3. Reduction of ordinary differential equations
4. Abstraction of the information flow
5. Model reduction
6. Conclusion

# Differential semantics

A system of ordinary differential equations is a pair  $(\mathcal{V}, \mathbb{F})$  where:

- $\mathcal{V}$  is a finite set of variables,
- $\mathbb{F}$  is a continuous function from  $\mathcal{V} \rightarrow \mathbb{R}^+$  to  $\mathcal{V} \rightarrow \mathbb{R}$ .

Elements of  $\mathcal{V} \rightarrow \mathbb{R}^+$  are called states.

The differential semantics maps each initial state  $X_0 \in \mathcal{V} \rightarrow \mathbb{R}^+$  to the solution  $X_{X_0} \in [0, T_{X_0}^{\max}[ \rightarrow (\mathcal{V} \rightarrow \mathbb{R}^+)$  of the following equation:

$$X_{X_0}(T) = X_0 + \int_{t=0}^T \mathbb{F}(X_{X_0}(t)) \cdot dt.$$

that is defined over the widest time interval as possible.

# Back to the case study

$$1. \mathcal{V} \triangleq \{[(u,u,u)], [(u,p,u)], [(p,p,u)], [(u,p,p)], [(p,p,p)]\},$$

$$2. \mathbb{F}(\rho) \triangleq \begin{cases} [(u,u,u)] \mapsto -k_c \cdot \rho([(u,u,u)]) \\ [(u,p,u)] \mapsto -k_g \cdot \rho([(u,p,u)]) + k_c \cdot \rho([(u,u,u)]) - k_d \cdot \rho([(u,p,u)]) \\ [(u,p,p)] \mapsto -k_g \cdot \rho([(u,p,p)]) + k_d \cdot \rho([(u,p,u)]) \\ [(p,p,u)] \mapsto k_g \cdot \rho([(u,p,u)]) - k_d \cdot \rho([(p,p,u)]) \\ [(p,p,p)] \mapsto k_g \cdot \rho([(u,p,p)]) + k_d \cdot \rho([(p,p,u)]). \end{cases}$$

# Abstraction

An abstraction is a 5-uple  $(\mathcal{V}, \mathbb{F}, \mathcal{V}^\#, \psi, \mathbb{F}^\#)$ , where:

- $(\mathcal{V}, \mathbb{F})$  is a system of ordinary equations,
- $\mathcal{V}^\#$  is a finite set of observables,
- $\psi$  is a function from the set  $\mathcal{V} \rightarrow \mathbb{R}$  into the set  $\mathcal{V}^\# \rightarrow \mathbb{R}$ ,
- $\mathbb{F}^\#$  is a function  $\mathcal{C}^\infty$  from the set  $\mathcal{V}^\# \rightarrow \mathbb{R}^+$  into the set  $\mathcal{V}^\# \rightarrow \mathbb{R}$ ;

such that:

- $\psi$  is linear with positive coefficients only and such that each variable  $v \in \mathcal{V}$  occurs in the image of at least one observable  $v^\# \in \mathcal{V}^\#$  with a non-zero coefficient;
- the following diagram commutes:

$$\begin{array}{ccc}
 (\mathcal{V} \rightarrow \mathbb{R}^+) & \xrightarrow{\mathbb{F}} & (\mathcal{V} \rightarrow \mathbb{R}) \\
 \psi \downarrow & & \downarrow \psi \\
 (\mathcal{V}^\# \rightarrow \mathbb{R}^+) & \xrightarrow{\mathbb{F}^\#} & (\mathcal{V}^\# \rightarrow \mathbb{R})
 \end{array}$$

that is to say that  $\psi \circ \mathbb{F} = \mathbb{F}^\# \circ \psi$ .

# Back to the case study

1.  $\mathcal{V} \triangleq \{[(u,u,u)], [(u,p,u)], [(p,p,u)], [(u,p,p)], [(p,p,p)]\}$
2.  $\mathbb{F}(\rho) \triangleq \begin{cases} [(u,u,u)] \mapsto -k_c \cdot \rho([(u,u,u)]) \\ [(u,p,u)] \mapsto -k_g \cdot \rho([(u,p,u)]) + k_c \cdot \rho([(u,u,u)]) - k_d \cdot \rho([(u,p,u)]) \\ [(u,p,p)] \mapsto -k_g \cdot \rho([(u,p,p)]) + k_d \cdot \rho([(u,p,u)]) \\ \dots \end{cases}$
3.  $\mathcal{V}^\# \triangleq \{[(u,u,u)], [(?,p,u)], [(?,p,p)], [(u,p,?)], [(p,p,?)]\}$
4.  $\psi(\rho) \triangleq \begin{cases} [(u,u,u)] \mapsto \rho([(u,u,u)]) \\ [(?,p,u)] \mapsto \rho([(u,p,u)]) + \rho([(p,p,u)]) \\ [(?,p,p)] \mapsto \rho([(u,p,p)]) + \rho([(p,p,p)]) \\ \dots \end{cases}$
5.  $\mathbb{F}^\#(\rho^\#) \triangleq \begin{cases} [(u,u,u)] \mapsto -k_c \cdot \rho^\#([(u,u,u)]) \\ [(?,p,u)] \mapsto -k_d \cdot \rho^\#([(?,p,u)]) + k_c \cdot \rho^\#([(u,u,u)]) \\ [(?,p,p)] \mapsto k_d \cdot \rho^\#([(?,p,u)]) \\ \dots \end{cases}$

# Let us apply the abstraction function

Let:

1.  $(\mathcal{V}, \mathbb{F}, \mathcal{V}^\#, \psi, \mathbb{F}^\#)$  be an abstraction,
2. and  $X_0 \in \mathcal{V} \rightarrow \mathbb{R}^+$  be an initial state.

We have, at any time  $T$  within the time interval  $[0, T_{X_0}^{\max}[$ :

$$X_{X_0}(T) = X_0 + \int_{t=0}^T \mathbb{F}(X_{X_0}(t)) \cdot dt.$$

So:

$$\psi(X_{X_0}(T)) = \psi \left( X_0 + \int_{t=0}^T \mathbb{F}(X_{X_0}(t)) \cdot dt \right).$$

# Let us push $\psi$ towards the right

Let:

1.  $(\mathcal{V}, \mathbb{F}, \mathcal{V}^\#, \psi, \mathbb{F}^\#)$  be an abstraction,
2. and  $X_0 \in \mathcal{V} \rightarrow \mathbb{R}^+$  be an initial state.

We have, at any time  $T$  within the time interval  $[0, T_{X_0}^{\max}[$ :

$$X_{X_0}(T) = X_0 + \int_{t=0}^T \mathbb{F}(X_{X_0}(t)) \cdot dt.$$

So:

$$\psi(X_{X_0}(T)) = \psi(X_0) + \psi \left( \int_{t=0}^T \mathbb{F}(X_{X_0}(t)) \cdot dt \right).$$

# Let us push $\psi$ towards the right

Let:

1.  $(\mathcal{V}, \mathbb{F}, \mathcal{V}^\#, \psi, \mathbb{F}^\#)$  be an abstraction,
2. and  $X_0 \in \mathcal{V} \rightarrow \mathbb{R}^+$  be an initial state.

We have, at any time  $T$  within the time interval  $[0, T_{X_0}^{\max}[$ :

$$X_{X_0}(T) = X_0 + \int_{t=0}^T \mathbb{F}(X_{X_0}(t)) \cdot dt.$$

So:

$$\psi(X_{X_0}(T)) = \psi(X_0) + \int_{t=0}^T [\psi \circ \mathbb{F}](X_{X_0}(t)) \cdot dt.$$



# Let us push $\psi$ towards the right

Let:

1.  $(\mathcal{V}, \mathbb{F}, \mathcal{V}^\#, \psi, \mathbb{F}^\#)$  be an abstraction,
2. and  $X_0 \in \mathcal{V} \rightarrow \mathbb{R}^+$  be an initial state.

We have, at any time  $T$  within the time interval  $[0, T_{X_0}^{\max}[$ :

$$X_{X_0}(T) = X_0 + \int_{t=0}^T \mathbb{F}(X_{X_0}(t)) \cdot dt.$$

So:

$$\psi(X_{X_0}(T)) = \psi(X_0) + \int_{t=0}^T [\mathbb{F}^\# \circ \psi](X_{X_0}(t)) \cdot dt.$$

# Let us push $\psi$ towards the right

Let:

1.  $(\mathcal{V}, \mathbb{F}, \mathcal{V}^\#, \psi, \mathbb{F}^\#)$  be an abstraction,
2. and  $X_0 \in \mathcal{V} \rightarrow \mathbb{R}^+$  be an initial state.

We have, at any time  $T$  within the time interval  $[0, T_{X_0}^{\max}[$ :

$$X_{X_0}(T) = X_0 + \int_{t=0}^T \mathbb{F}(X_{X_0}(t)) \cdot dt.$$

So:

$$\psi(X_{X_0}(T)) = \psi(X_0) + \int_{t=0}^T \mathbb{F}^\#(\psi(X_{X_0}(t))) \cdot dt.$$

# Abstract semantics

Let  $(\mathcal{V}, \mathbb{F}, \mathcal{V}^\#, \psi, \mathbb{F}^\#)$  be an abstraction.

The couple  $(\mathcal{V}^\#, \mathbb{F}^\#)$  is a system of differential equations.

Let us denote by  $Y$  its semantics.

For each state  $Y_0 \in \mathcal{V}^\# \rightarrow \mathbb{R}^+$ , we denote by  $[0, T_{Y_0}^{\# \max}[$  the domain of the function  $Y_{Y_0}$ . We have, at any time  $T^\# \in [0, T_{X_0}^{\# \max}[$ ,

$$Y_{Y_0}(T^\#) = Y_0 + \int_{t=0}^{T^\#} \mathbb{F}^\#(Y_{Y_0}(t)) \cdot dt.$$

**Theorem 1** For each initial state  $X_0 \in \mathcal{V} \rightarrow \mathbb{R}^+$ , we have:

1.  $T_{\psi(X_0)}^{\# \max} = T_{X_0}^{\max}$ ;
2. at any time  $T \in [0, T_{X_0}^{\max}[$ ,  $\psi(X_{X_0}(T)) = Y_{\psi(X_0)}(T)$ .

That is to say that the abstract semantics is the image of the concrete semantics by the abstraction function.

# Abstract trajectories

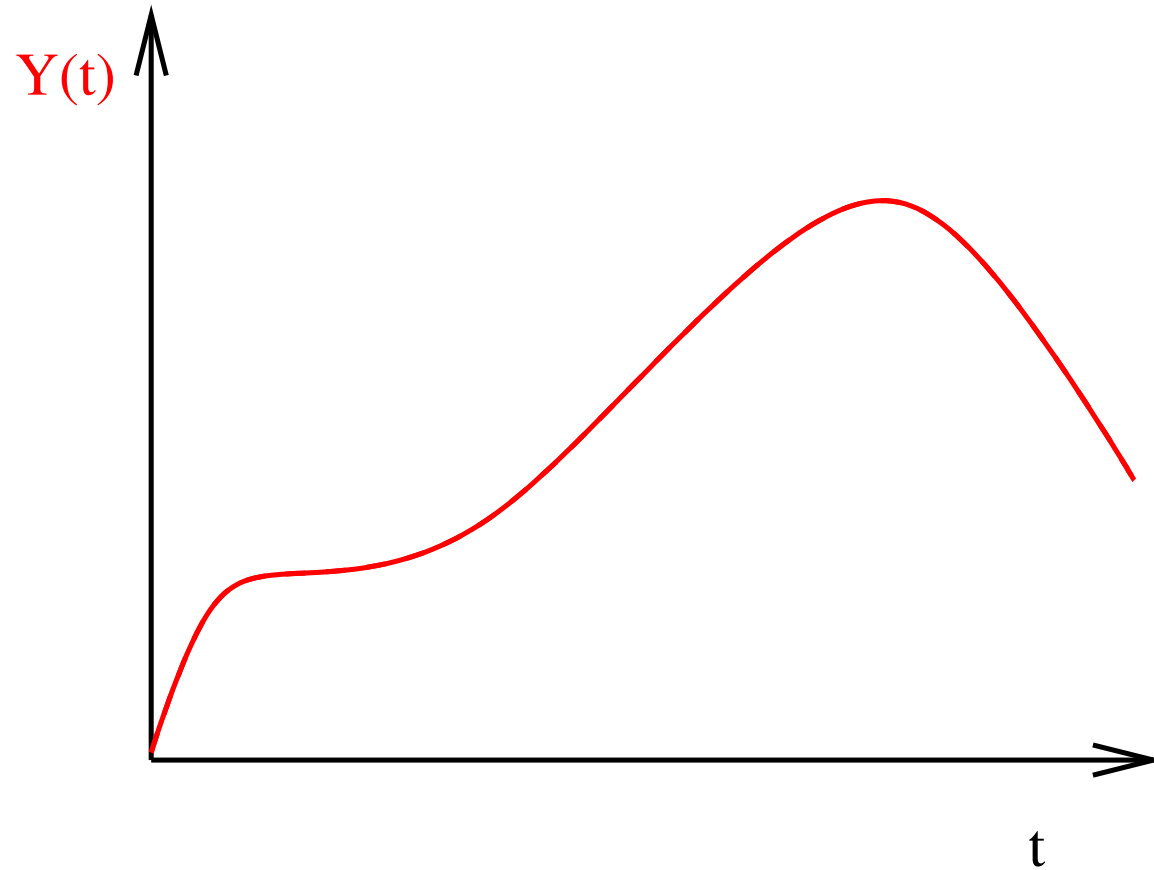

# Concrete trajectories

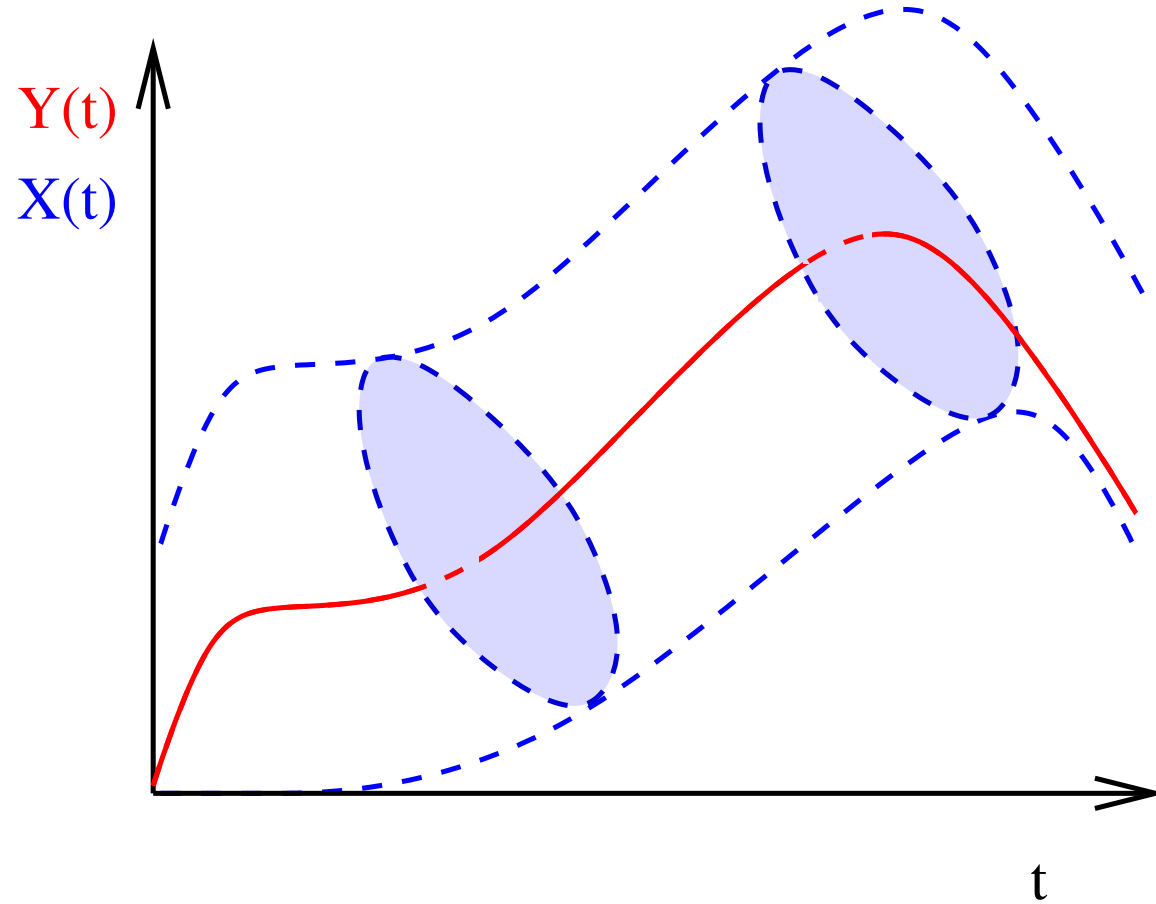

# A model with symmetries

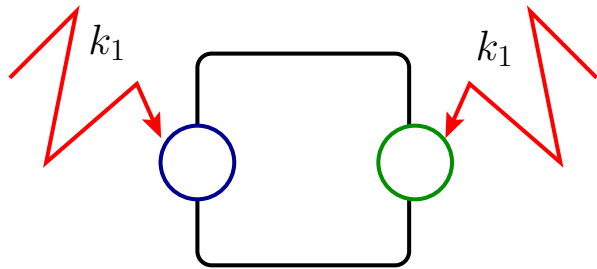

$$\begin{array}{l}
 P \longrightarrow {}^*P \quad k_1 \\
 P \longrightarrow P^* \quad k_1
 \end{array}$$

$$\begin{array}{l}
 P^* \longrightarrow {}^*P^* \quad k_1 \\
 {}^*P \longrightarrow {}^*P^* \quad k_1
 \end{array}$$

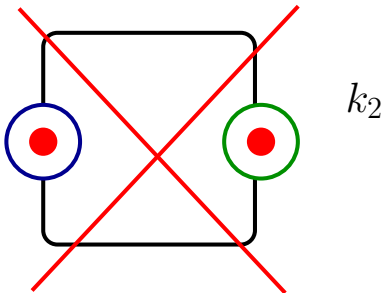

$${}^*P^* \longrightarrow \emptyset \quad k_2$$

# Differential equations

- Initial system:

$$\frac{d}{dt} \begin{bmatrix} P \\ *P \\ P^* \\ *P^* \end{bmatrix} = \begin{bmatrix} -2 \cdot k_1 & 0 & 0 & 0 \\ k_1 & -k_1 & 0 & 0 \\ k_1 & 0 & -k_1 & 0 \\ 0 & k_1 & k_1 & -k_2 \end{bmatrix} \cdot \begin{bmatrix} P \\ *P \\ P^* \\ *P^* \end{bmatrix}$$

- Reduced system:

$$\frac{d}{dt} \begin{bmatrix} P \\ *P + P^* \\ 0 \\ *P^* \end{bmatrix} = \begin{bmatrix} -2 \cdot k_1 & 0 & 0 & 0 \\ 2 \cdot k_1 & -k_1 & 0 & 0 \\ 0 & 0 & 0 & 0 \\ 0 & k_1 & 0 & -k_2 \end{bmatrix} \cdot \begin{bmatrix} P \\ *P + P^* \\ 0 \\ *P^* \end{bmatrix}$$

# Differential equations

- Initial system:

$$\frac{d}{dt} \begin{bmatrix} P \\ *P \\ P^* \\ *P^* \end{bmatrix} = \begin{bmatrix} -2 \cdot k_1 & 0 & 0 & 0 \\ k_1 & -k_1 & 0 & 0 \\ k_1 & 0 & -k_1 & 0 \\ 0 & k_1 & k_1 & -k_2 \end{bmatrix} \cdot \begin{bmatrix} P \\ *P \\ P^* \\ *P^* \end{bmatrix}$$

- Reduced system:

$$\frac{d}{dt} \begin{bmatrix} P \\ *P + P^* \\ 0 \\ *P^* \end{bmatrix} = \underbrace{\begin{bmatrix} 1 & 0 & 0 & 0 \\ 0 & 1 & 1 & 0 \\ 0 & 0 & 0 & 0 \\ 0 & 0 & 0 & 1 \end{bmatrix}}_P \cdot \begin{bmatrix} -2 \cdot k_1 & 0 & 0 & 0 \\ k_1 & -k_1 & 0 & 0 \\ k_1 & 0 & -k_1 & 0 \\ 0 & k_1 & k_1 & -k_2 \end{bmatrix} \cdot \underbrace{\begin{bmatrix} 1 & 0 & 0 & 0 \\ 0 & 1 & 0 & 0 \\ 0 & 0 & 0 & 0 \\ 0 & 0 & 0 & 1 \end{bmatrix}}_Z \cdot \begin{bmatrix} P \\ *P + P^* \\ 0 \\ *P^* \end{bmatrix}$$



# Pair of projections induced by an equivalence relation among variables

Let  $r$  be an idempotent mapping from  $\mathcal{V}$  to  $\mathcal{V}$ .

We define two linear projections  $P_r, Z_r \in (\mathcal{V} \rightarrow \mathbb{R}^+) \rightarrow (\mathcal{V} \rightarrow \mathbb{R}^+)$  by:

- $P_r(\rho)(V) = \begin{cases} \sum \{\rho(V') \mid r(V') = r(V)\} & \text{when } V = r(V) \\ 0 & \text{when } V \neq r(V); \end{cases}$
- $Z_r(\rho) = \begin{cases} V \mapsto \rho(V) & \text{when } V = r(V) \\ V \mapsto 0 & \text{when } V \neq r(V). \end{cases}$

We notice that the following diagram commutes:

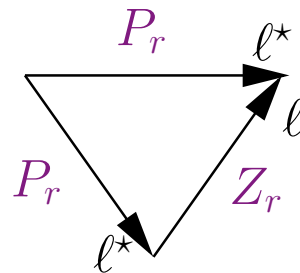

# Induced bisimulation

The mapping  $r$  induces a bisimulation,



for any  $\sigma, \sigma' \in \mathcal{V} \rightarrow \mathbb{R}^+$ ,  $P_r(\sigma) = P_r(\sigma') \implies P_r(\mathbb{F}(\sigma)) = P_r(\mathbb{F}(\sigma'))$ .

Indeed the mapping  $r$  induces a bisimulation,



for any  $\sigma \in \mathcal{V} \rightarrow \mathbb{R}^+$ ,  $P_r(\mathbb{F}(\sigma)) = P_r(\mathbb{F}(P_r(\sigma)))$ .

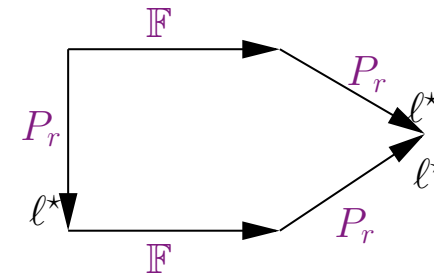

# Induced abstraction

Under these assumptions  $(r(\mathcal{V}), P_r, P_r \circ \mathbb{F} \circ Z_r)$  is an abstraction of  $(\mathcal{V}, \mathbb{F})$ , as proved in the following commutative diagram:

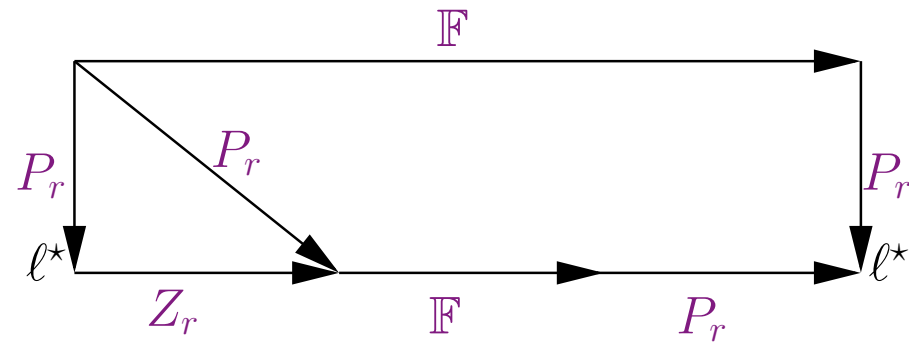

# Abstract projection

We assume that we are given:

- a concrete system  $(\mathcal{V}, \mathbb{F})$ ;
- an abstraction  $(\mathcal{V}^\#, \psi, \mathbb{F}^\#)$  of  $(\mathcal{V}, \mathbb{F})$  (I);
- an idempotent mapping  $r$  over  $\mathcal{V}$  which induces a bisimulation (II);
- an idempotent mapping  $r^\#$  over  $\mathcal{V}^\#$  (III);

such that:  $\psi \circ P_r = P_{r^\#} \circ \psi$  (IV).

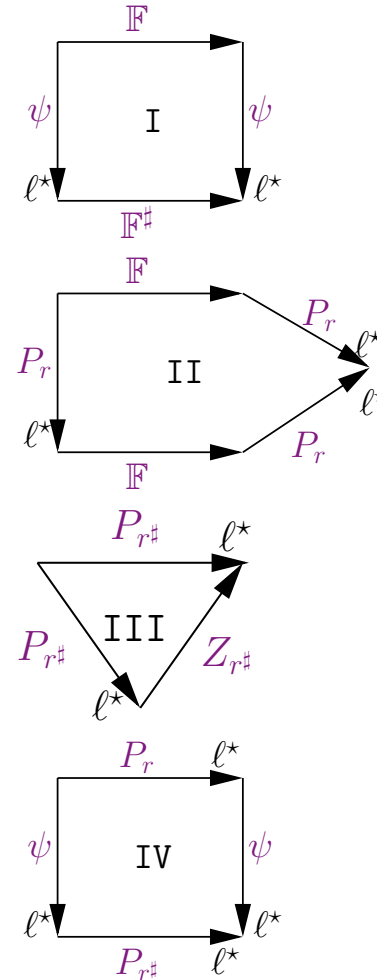

# Combination of abstractions

Under these assumptions,  $(r^\sharp(\mathcal{V}^\sharp), P_{r^\sharp} \circ \psi, P_{r^\sharp} \circ \mathbb{F}^\sharp \circ Z_{r^\sharp})$  is an abstraction of  $(\mathcal{V}, \mathbb{F})$ , as proved in the following commutative diagram:

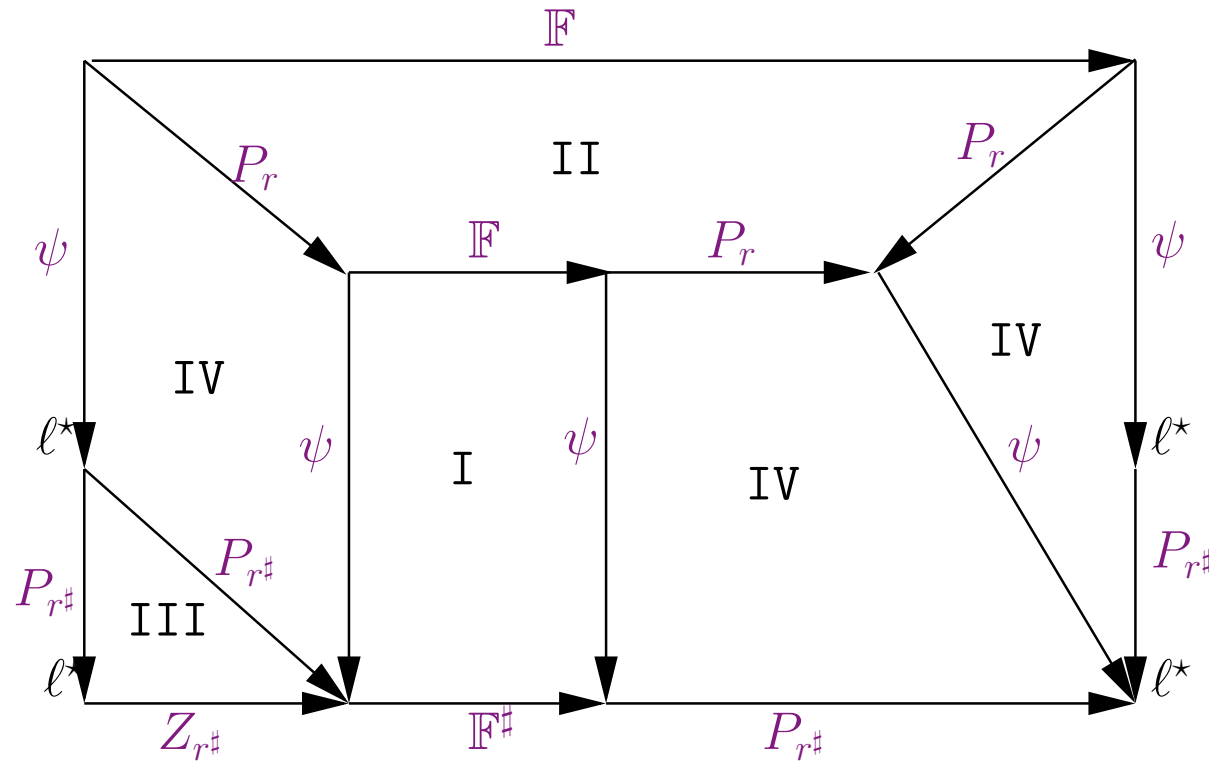

# On the menu today

1. Context and motivations
2. Case studies
3. Reduction of ordinary differential equations
4. Abstraction of the information flow
5. Model reduction
6. Conclusion

# Concrete semantics

A rule is a symbolic representation of a multi-set of reactions.

For instance, the rule:

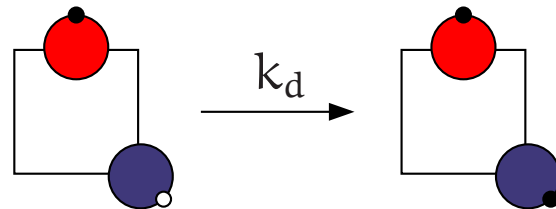

denotes the following two rules:

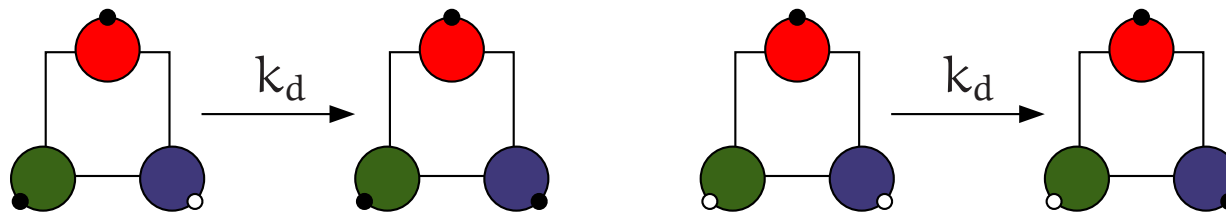

The semantics of a set of rules is the semantics of the underlying multi-set of reactions.

# Flow of information (in the concrete)

Does the state of a given site influence the capability to modify another site?

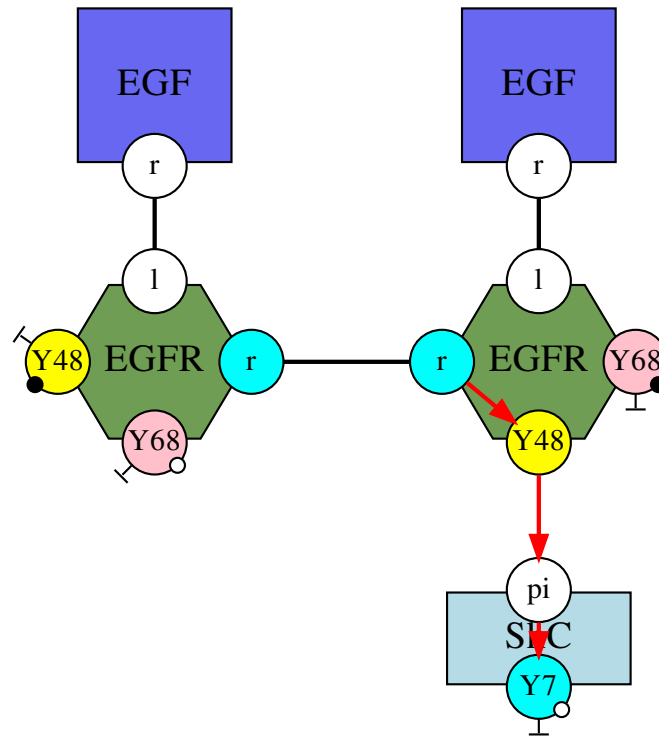



# Flow of information (in the concrete)

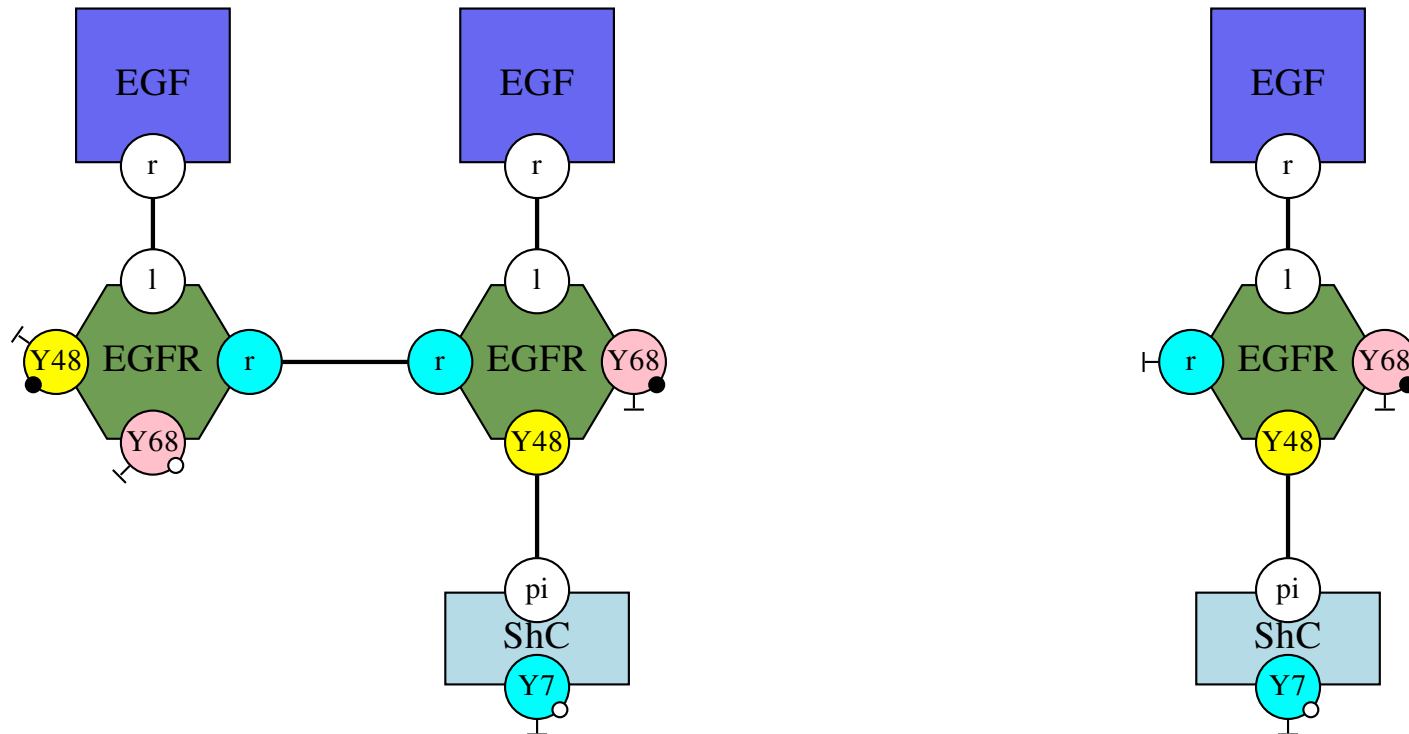

# Flow of information (in the concrete)

If there exists a soup of chemical species in which the activation rate of the site of *ShC* is different in these two contexts, then there may be a flow of information.

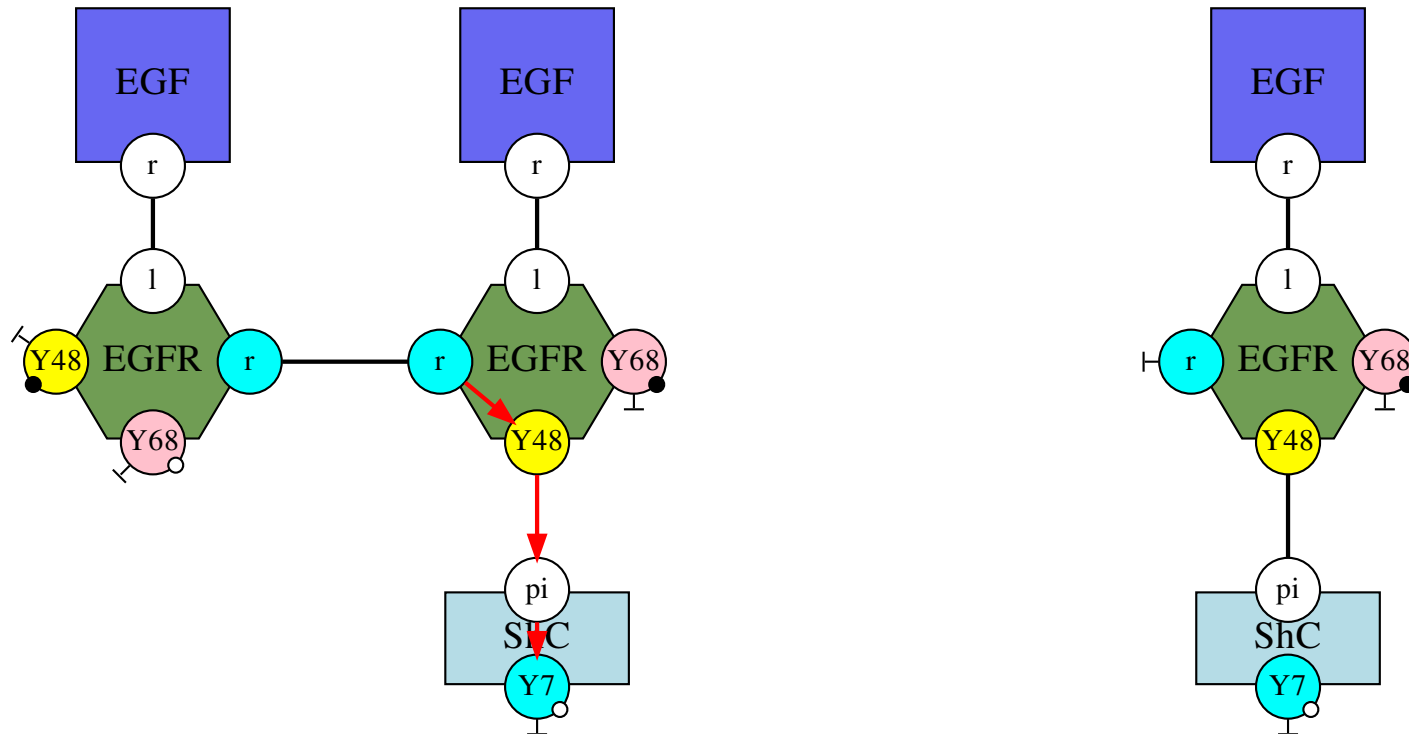

# Discrimination by a rule

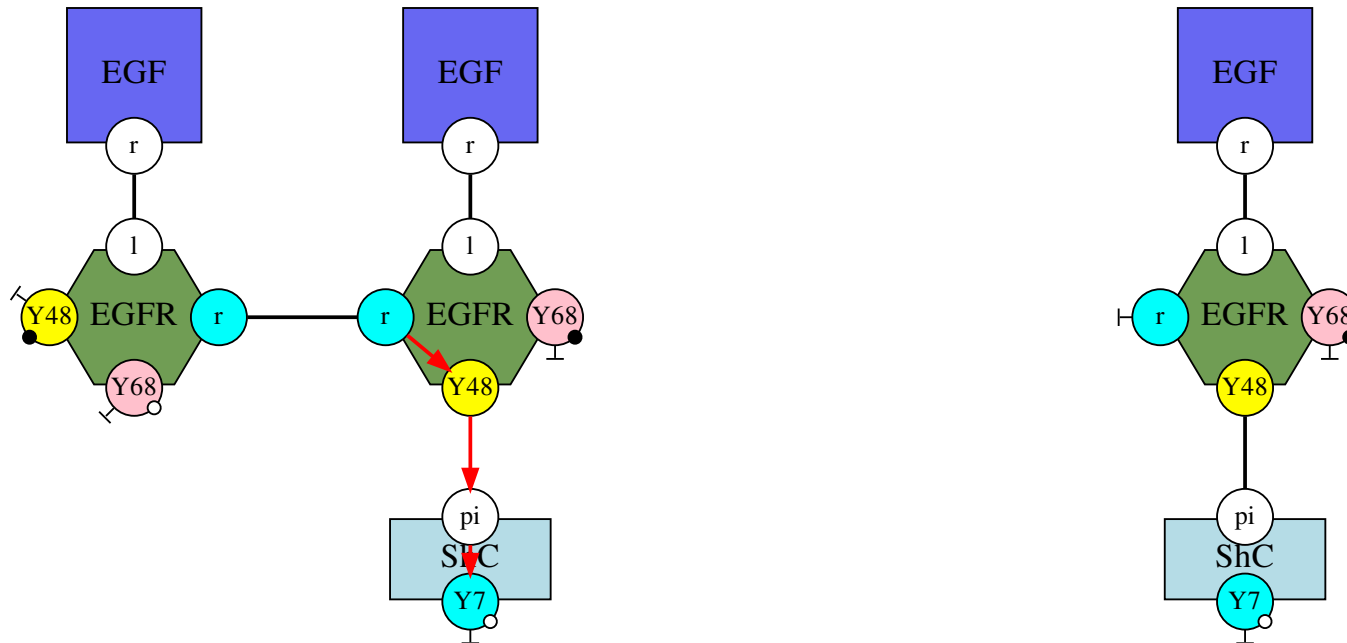

In this case, there exists a rule which makes a difference between these two contexts, for instance the following one:

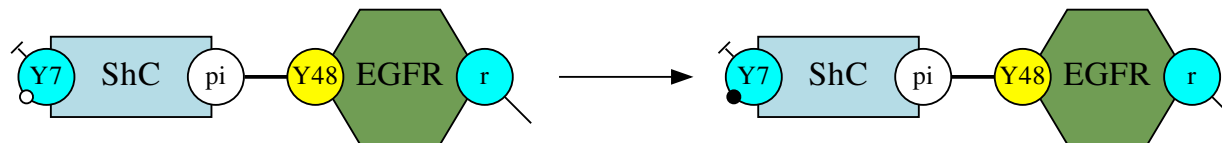

# Flow of information due to a rule

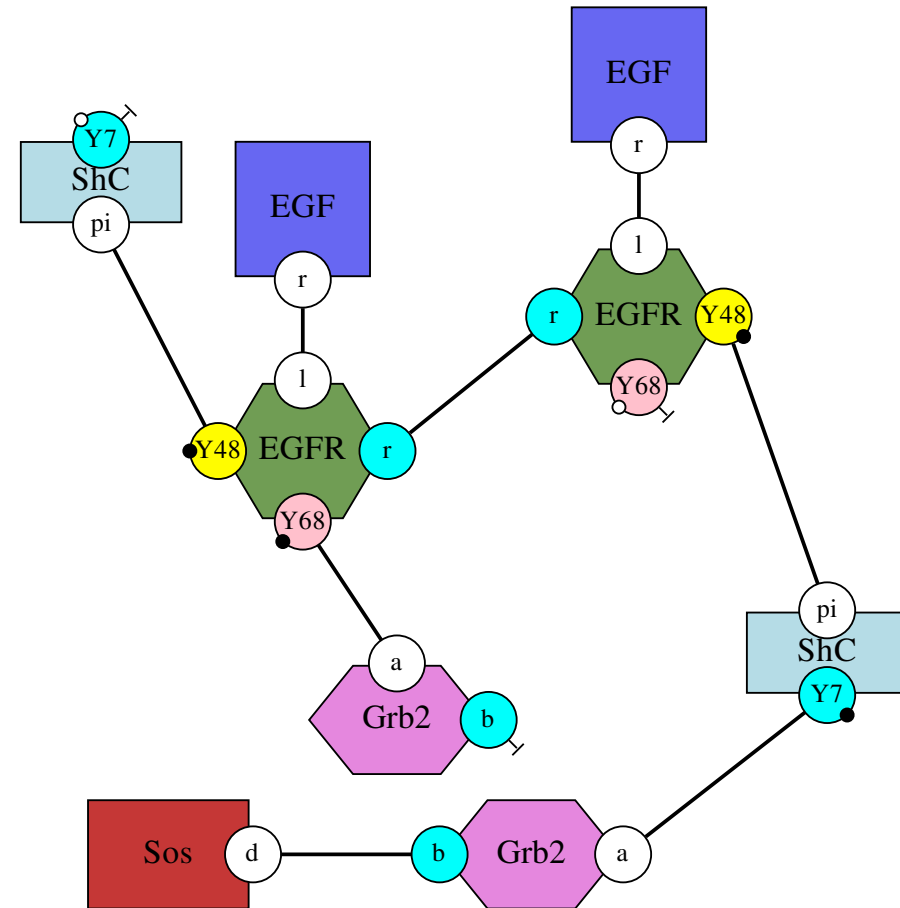
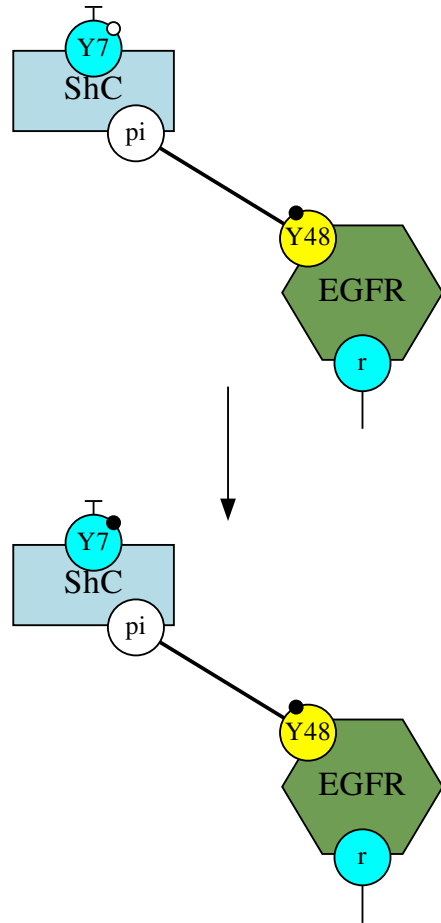

# Flow of information due to a rule

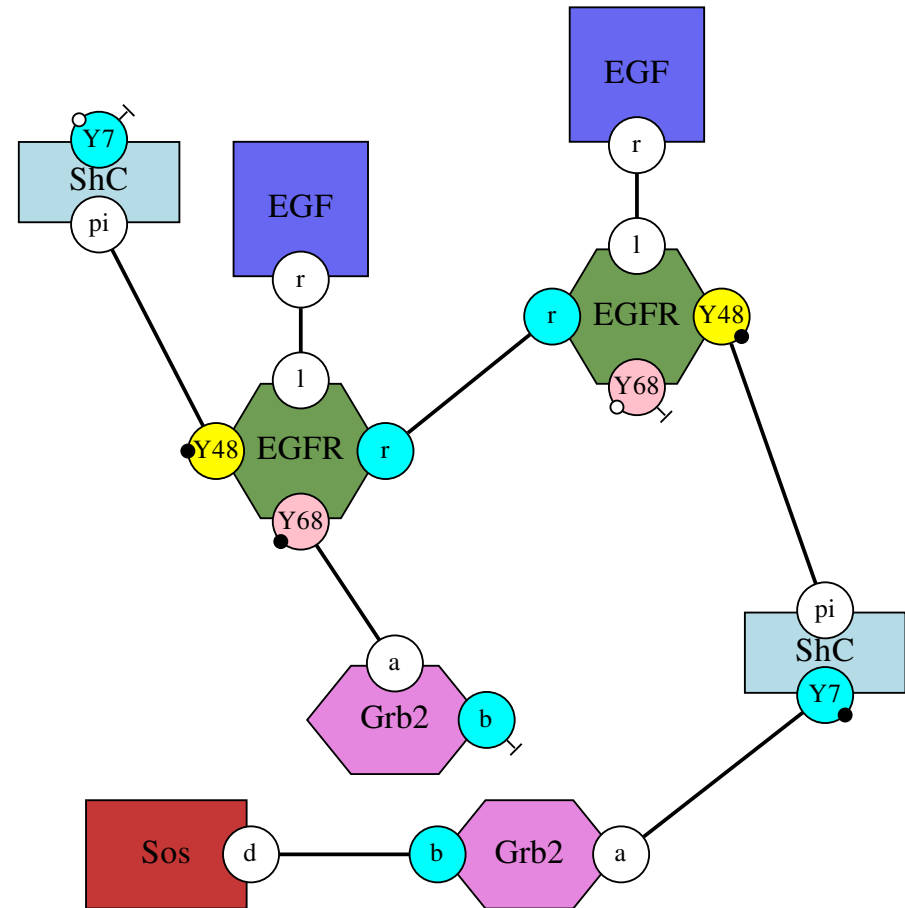
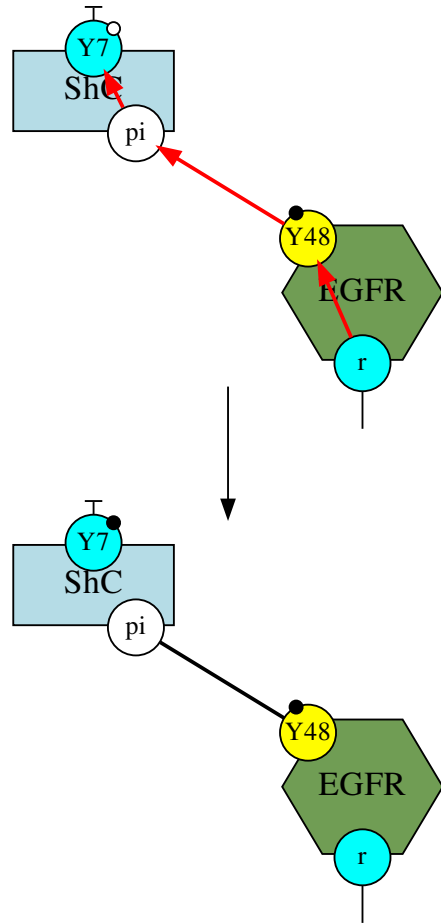



# Flow of information due to a rule

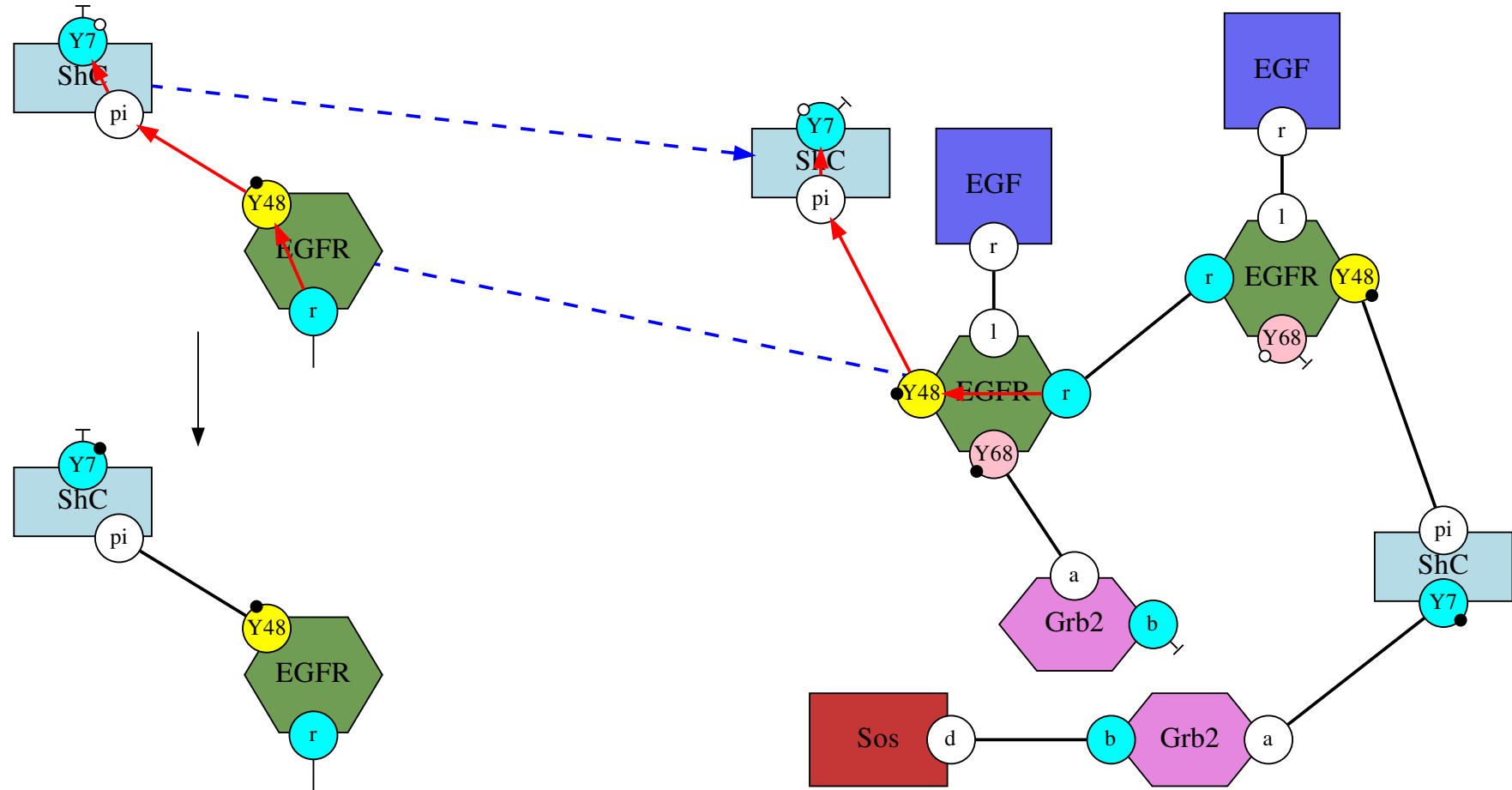

# Flow of information due to a rule

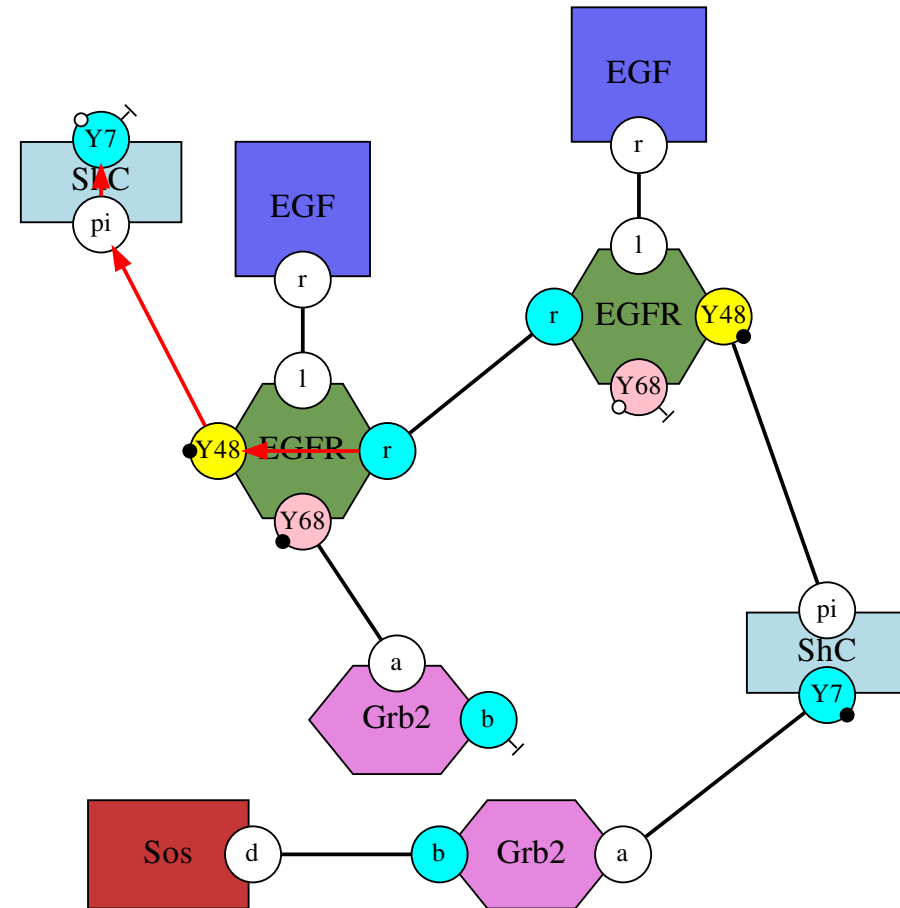
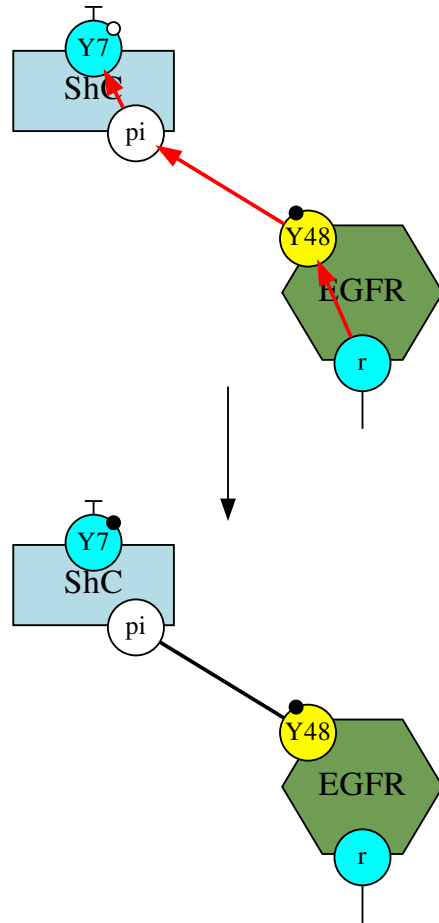



# Projection on the contact map

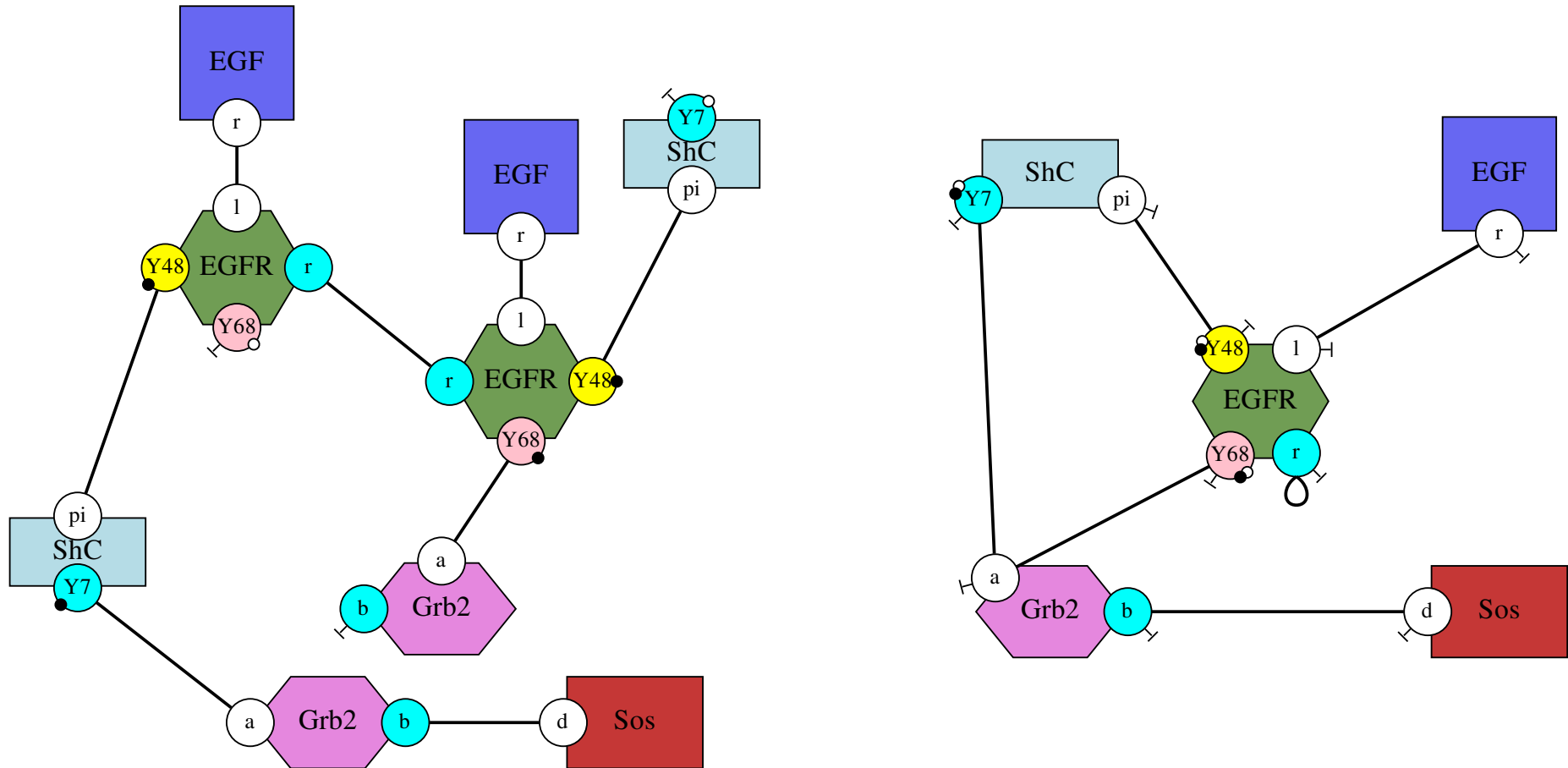

# Projection on the contact map

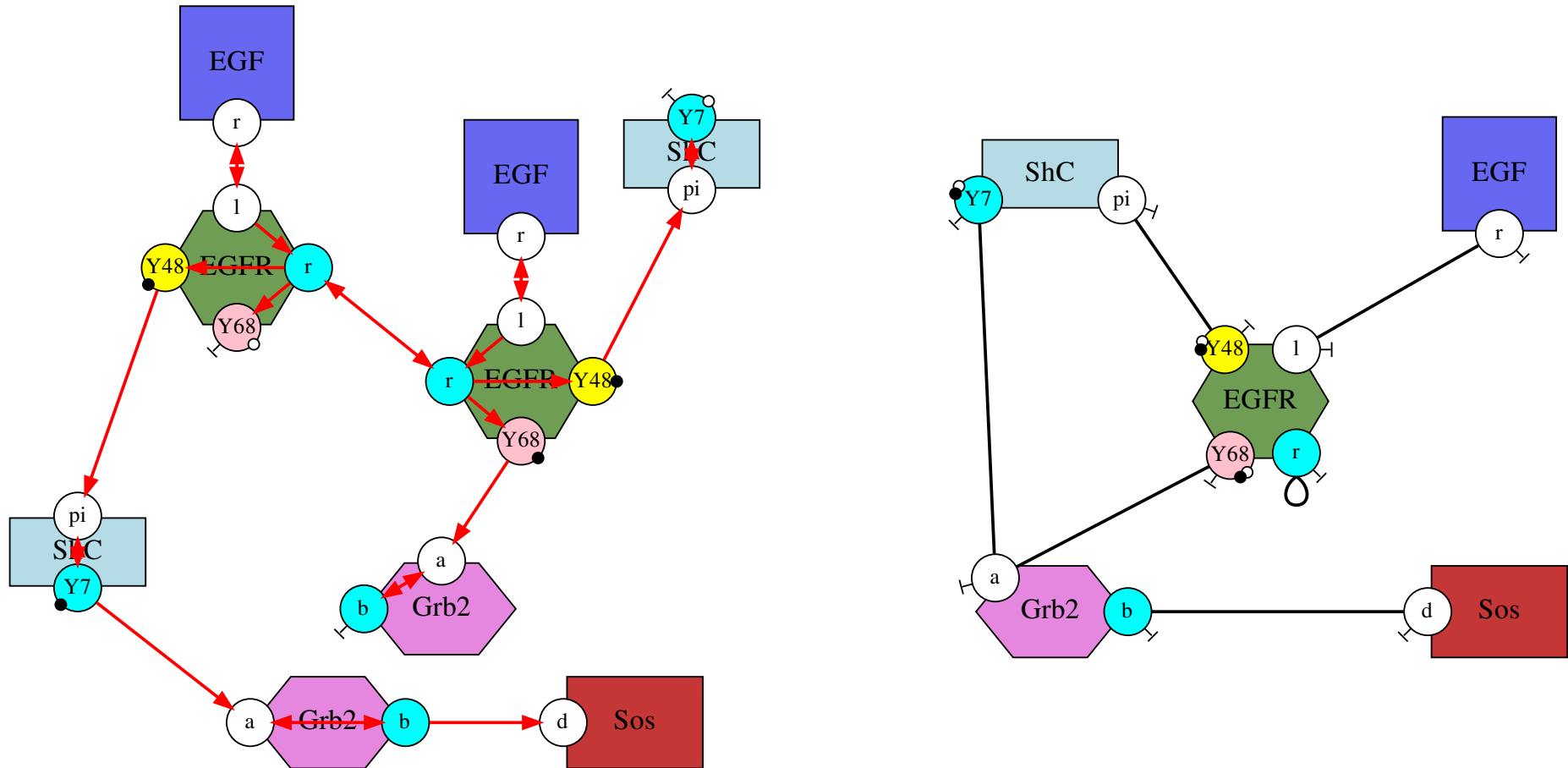

# Projection on the contact map

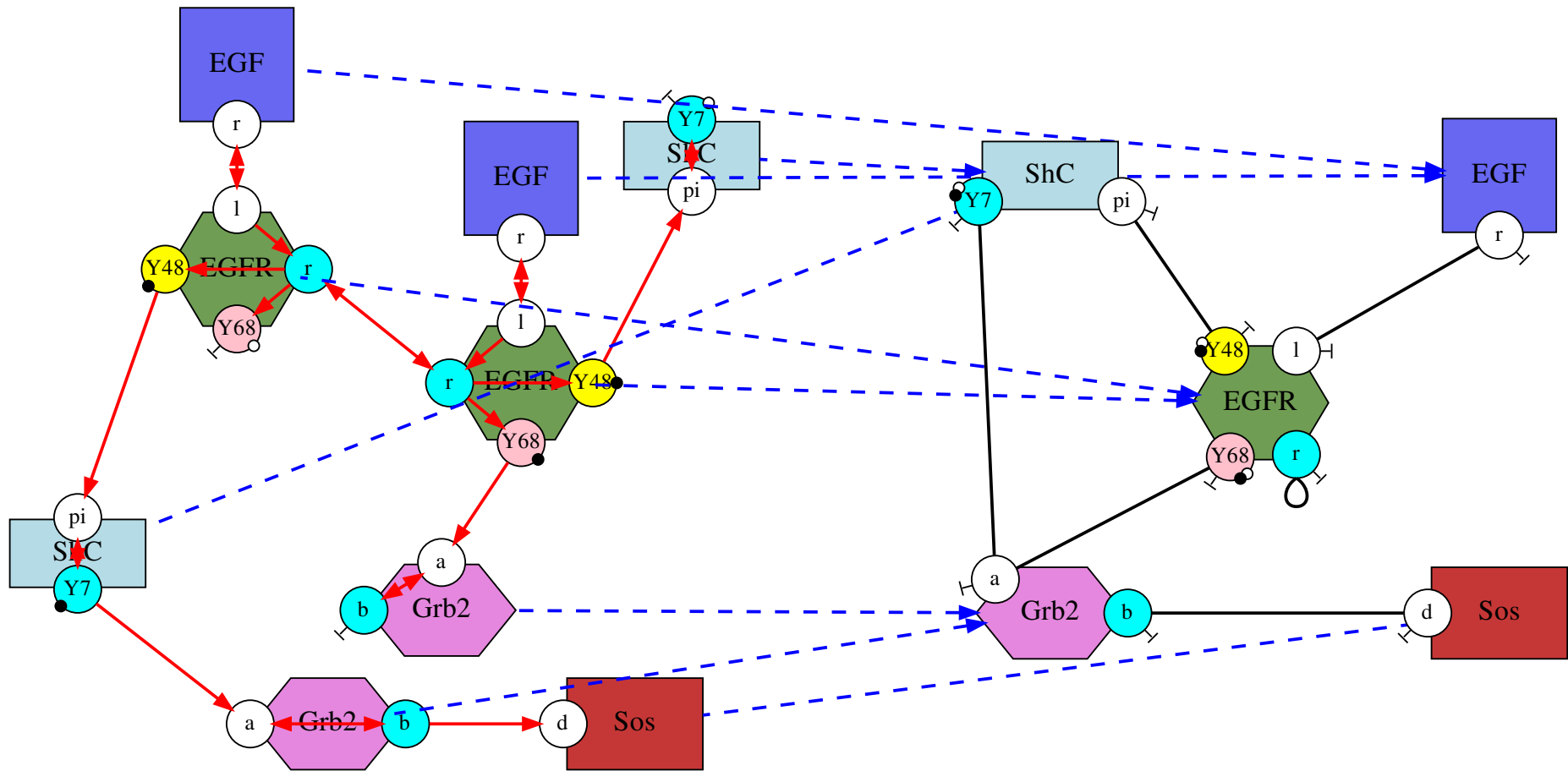

# Projection on the contact map

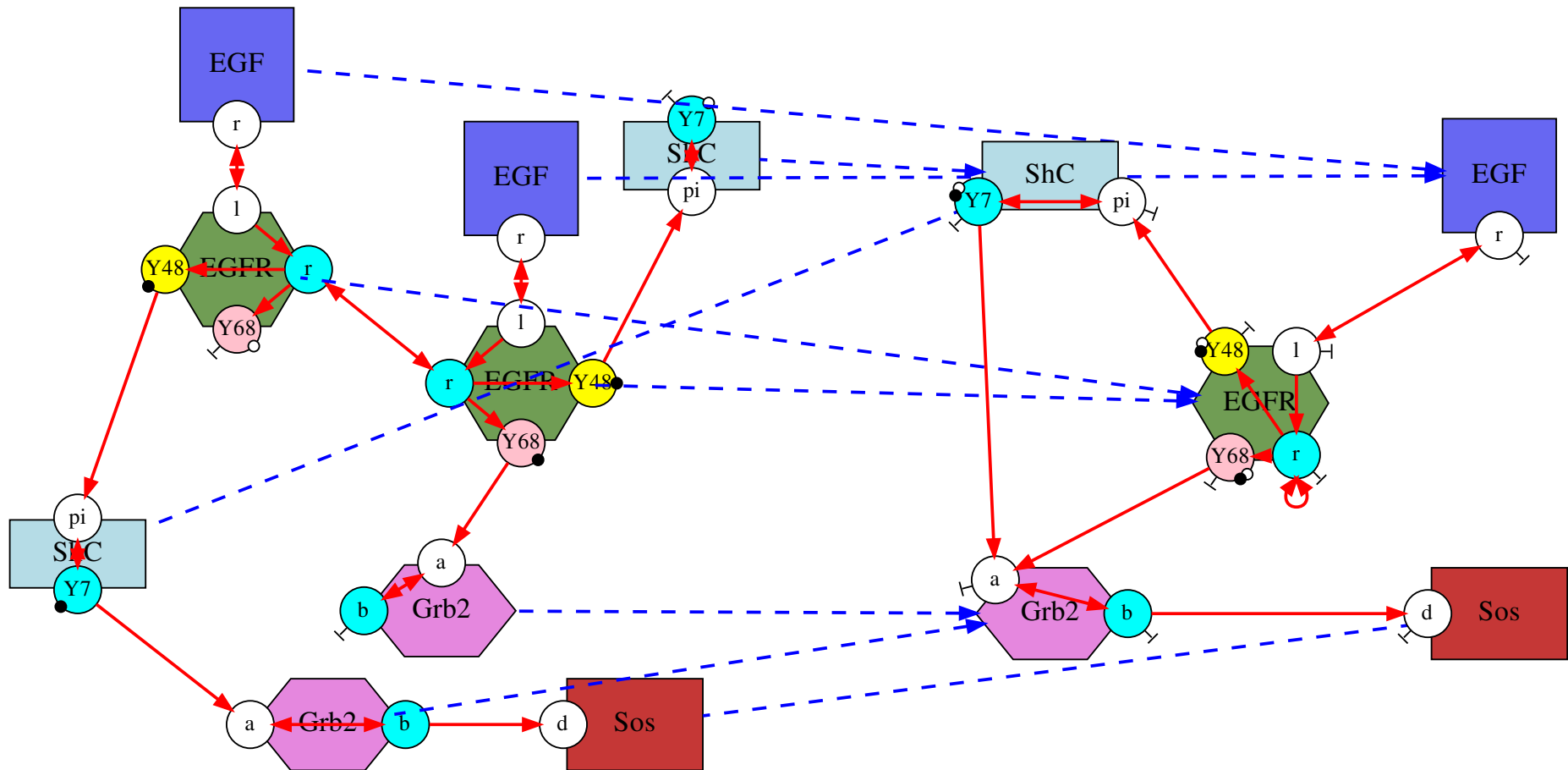

# Projection on the contact map

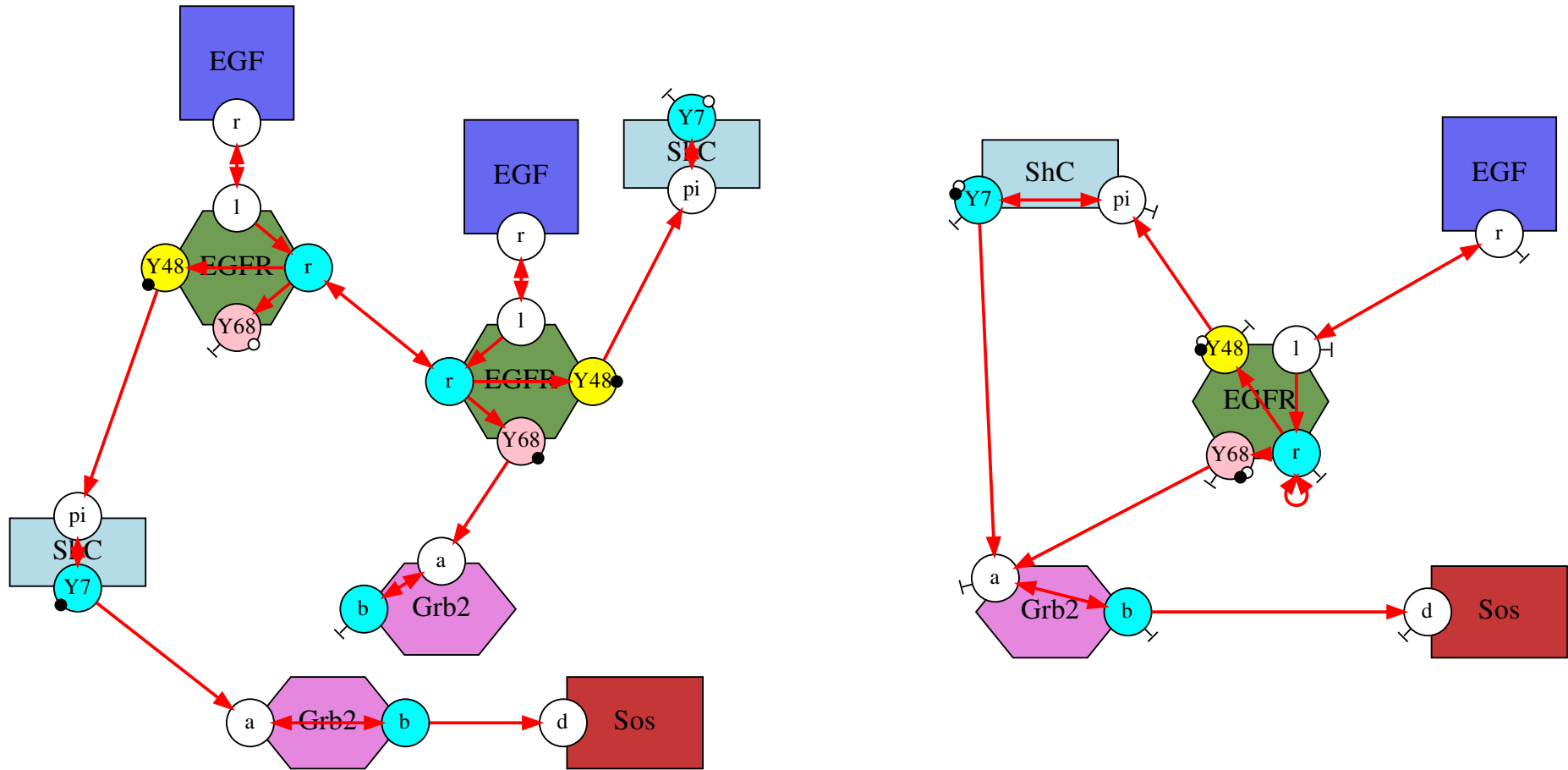

# Direct computation

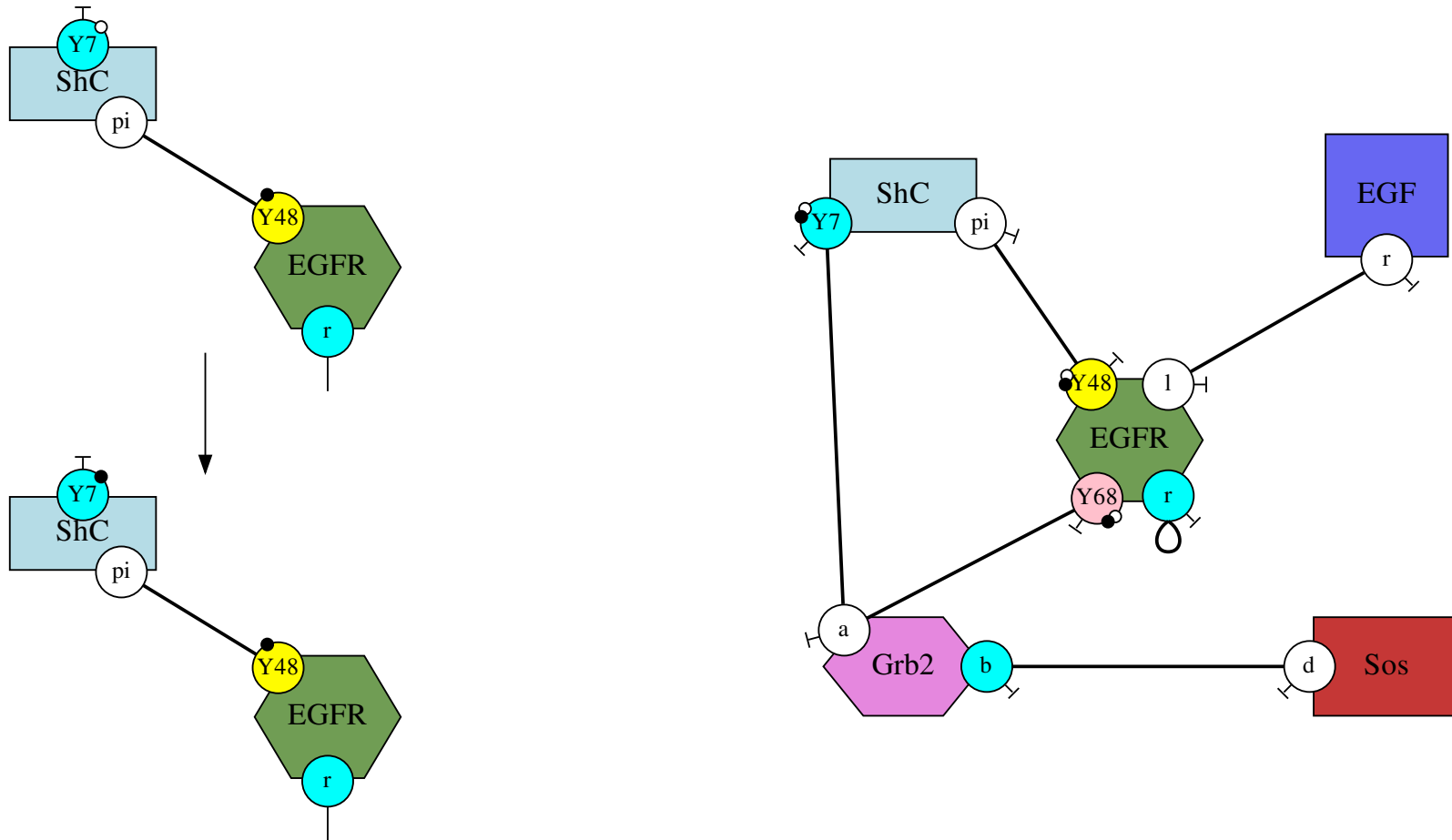

# Direct computation

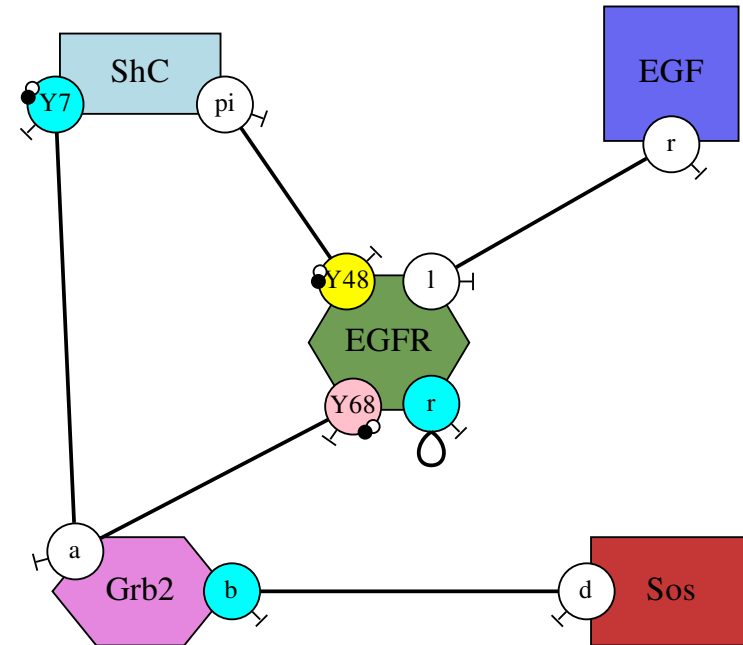
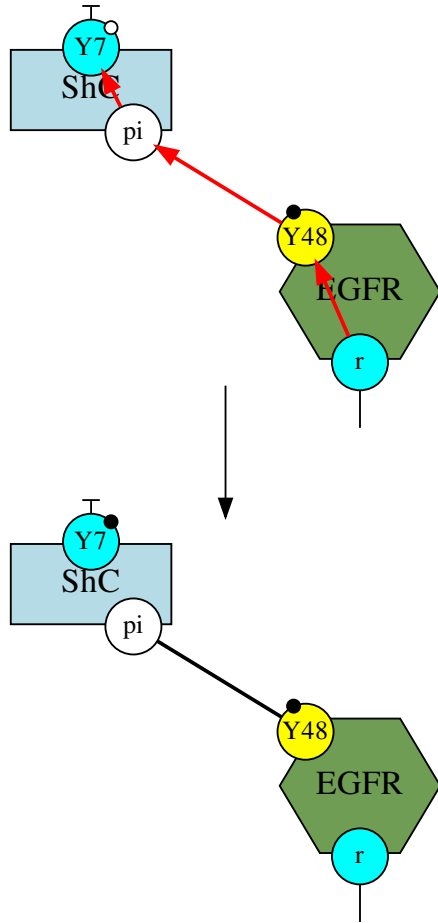

# Direct computation

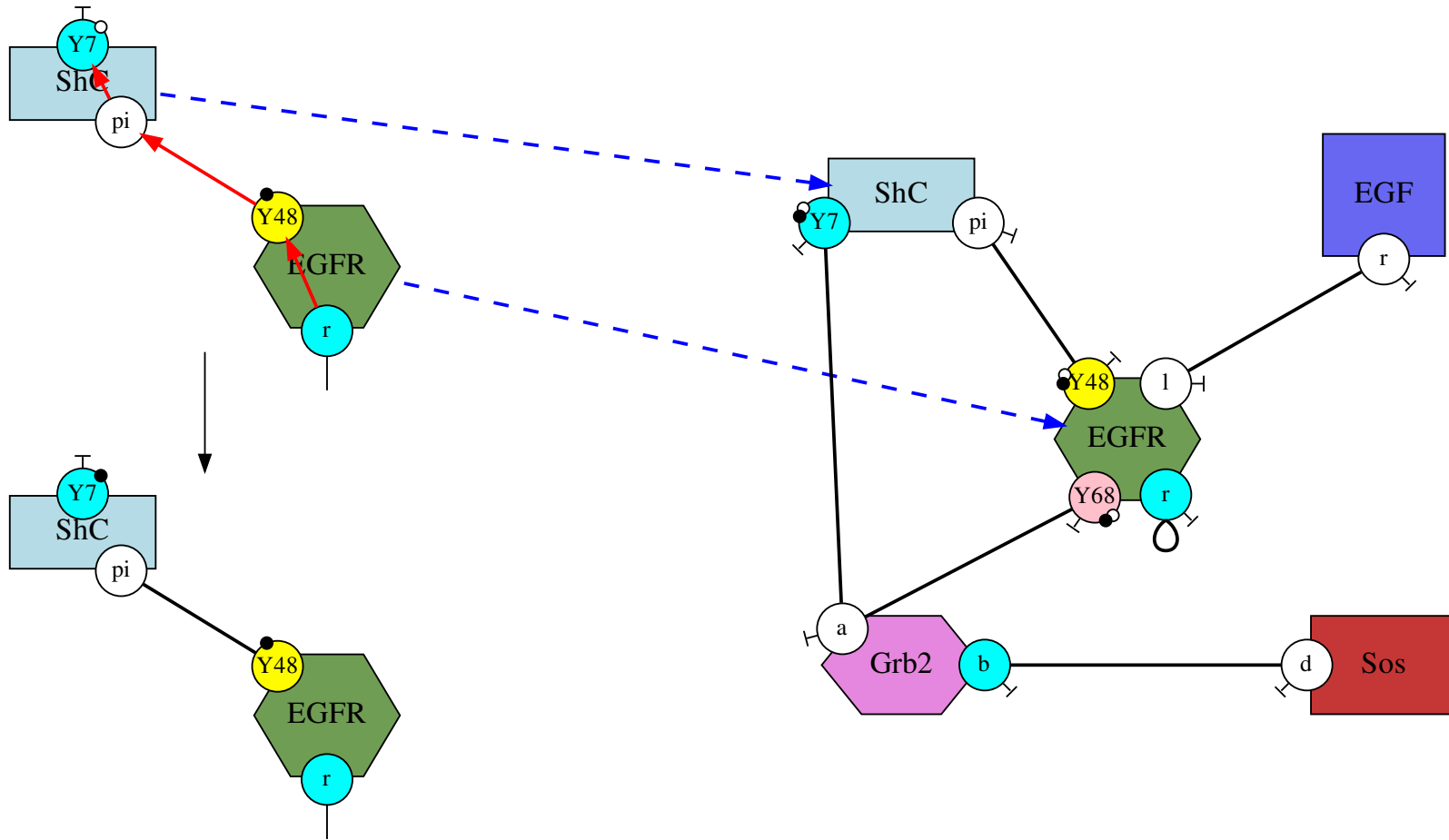







# On the menu today

1. Context and motivations
2. Case studies
3. Reduction of ordinary differential equations
4. Abstraction of the information flow
5. **Model reduction**
6. Conclusion

# Which patterns shall we keep?

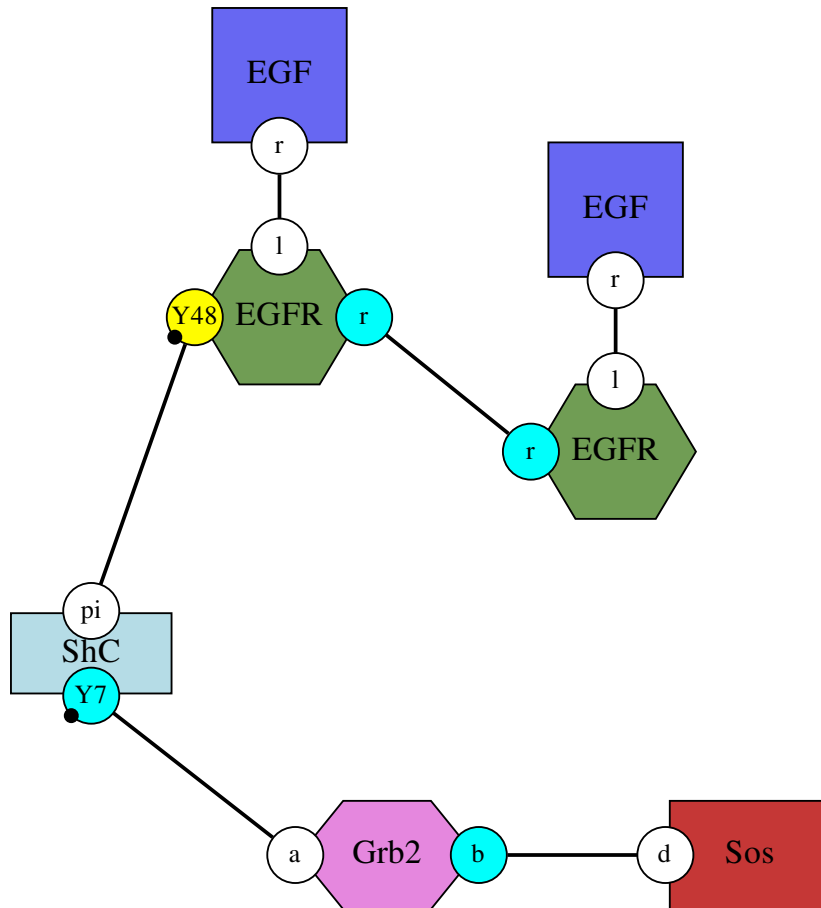

# Which patterns shall we keep?

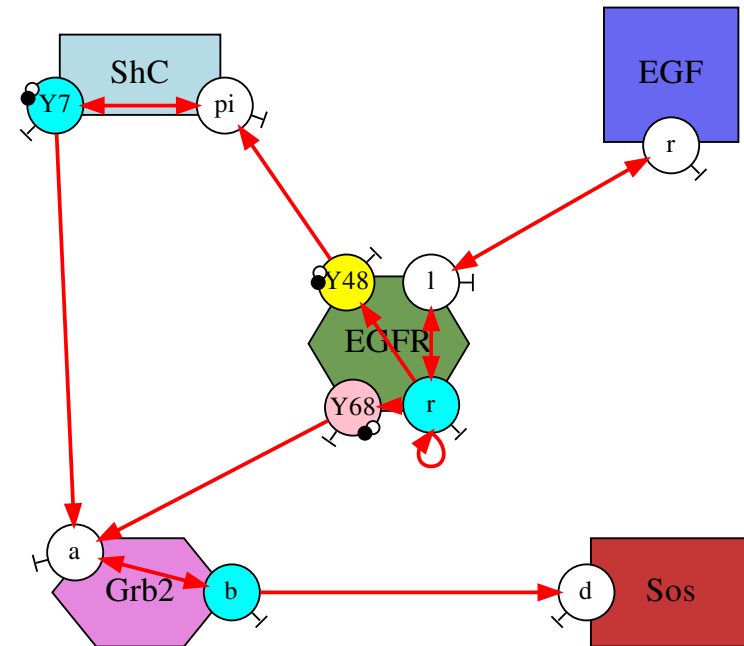
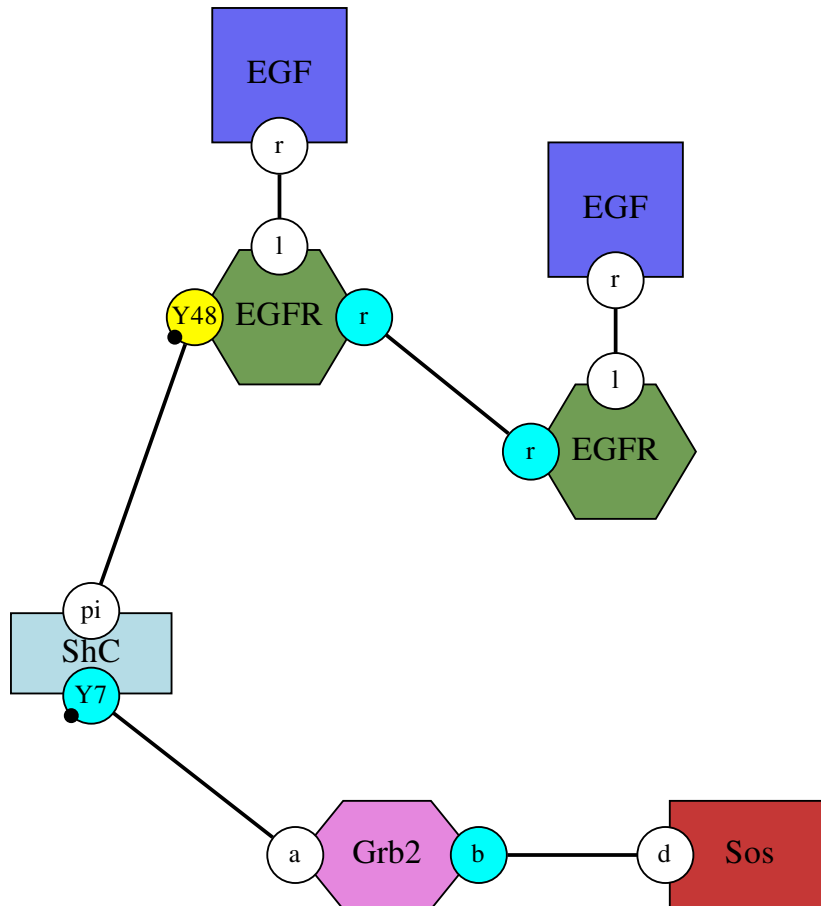

# Pattern annotation

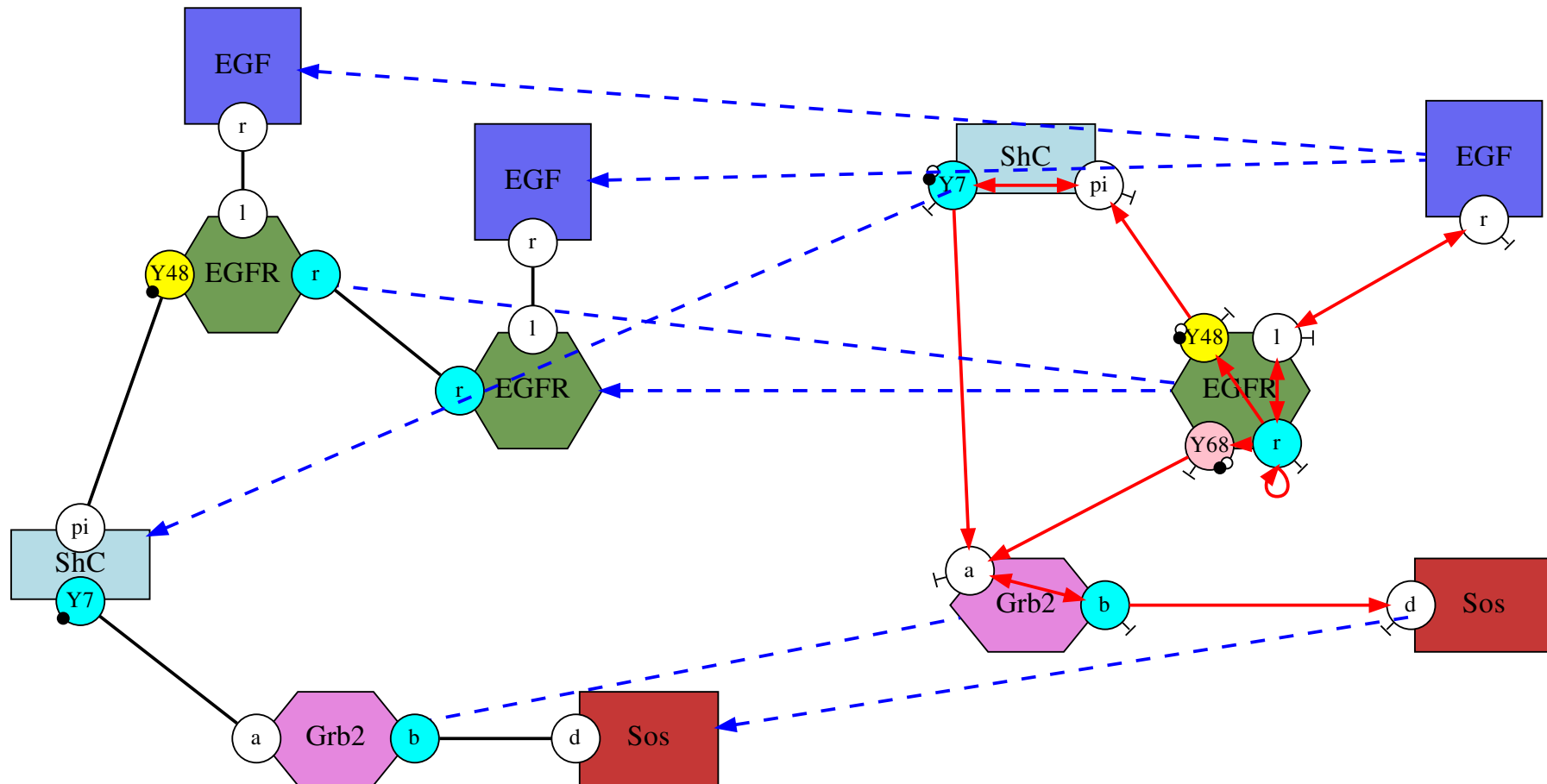

# Pattern annotation

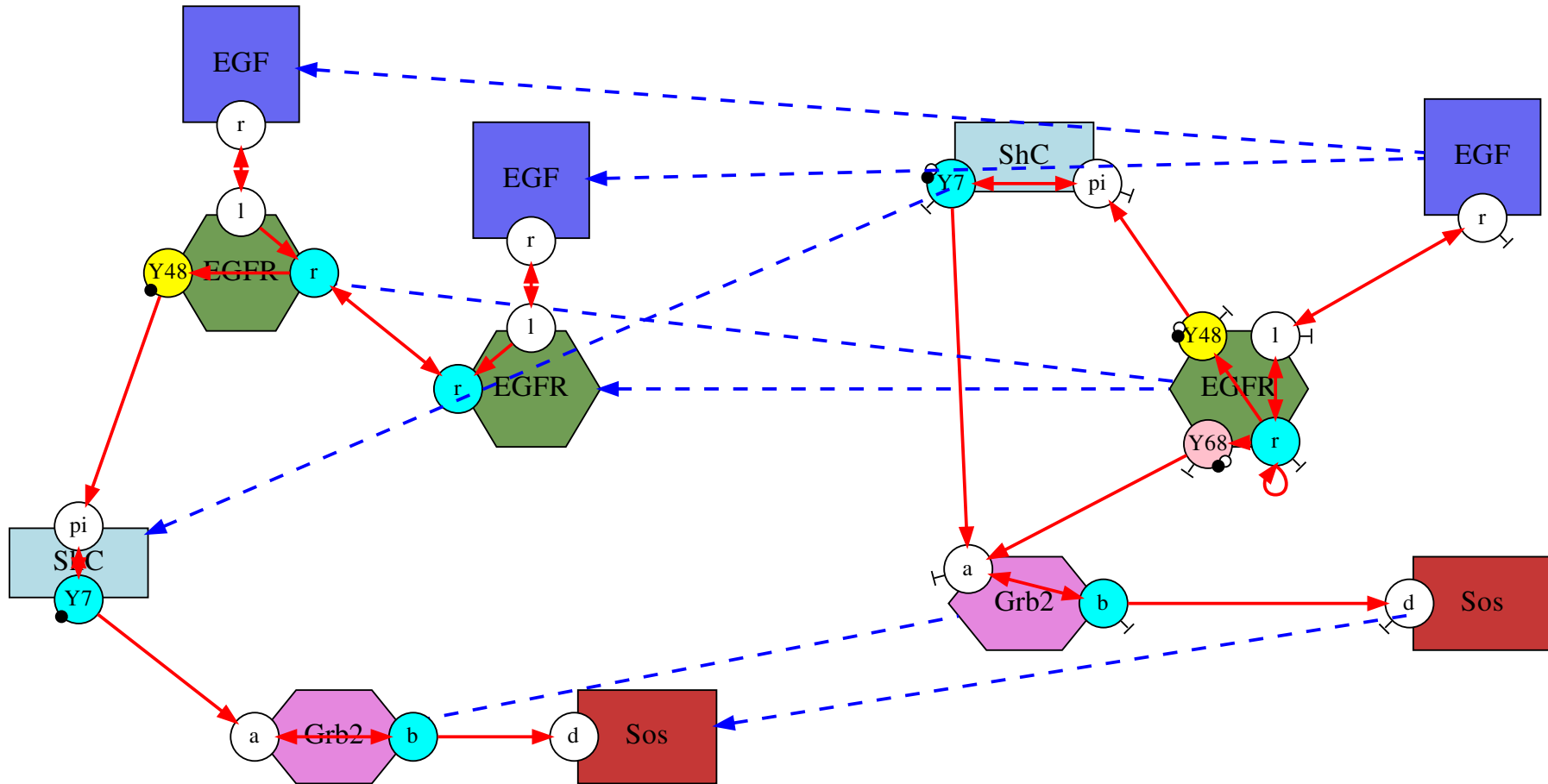

# Prefragment

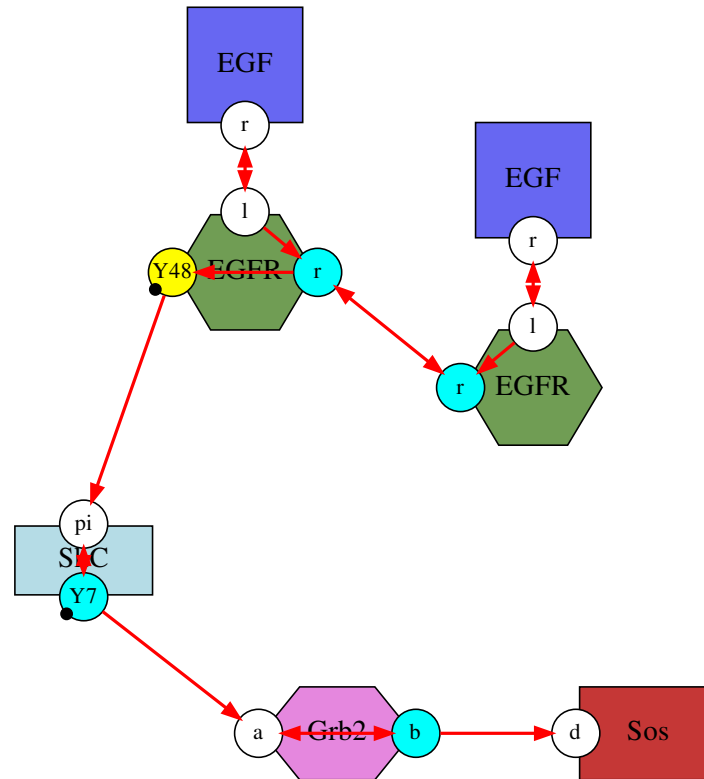

**Definition 1 (prefragment)** A pattern is a prefragment if, in its annotated form, there exists a site that it is reachable from every site (following the flow of information).



# Fragments

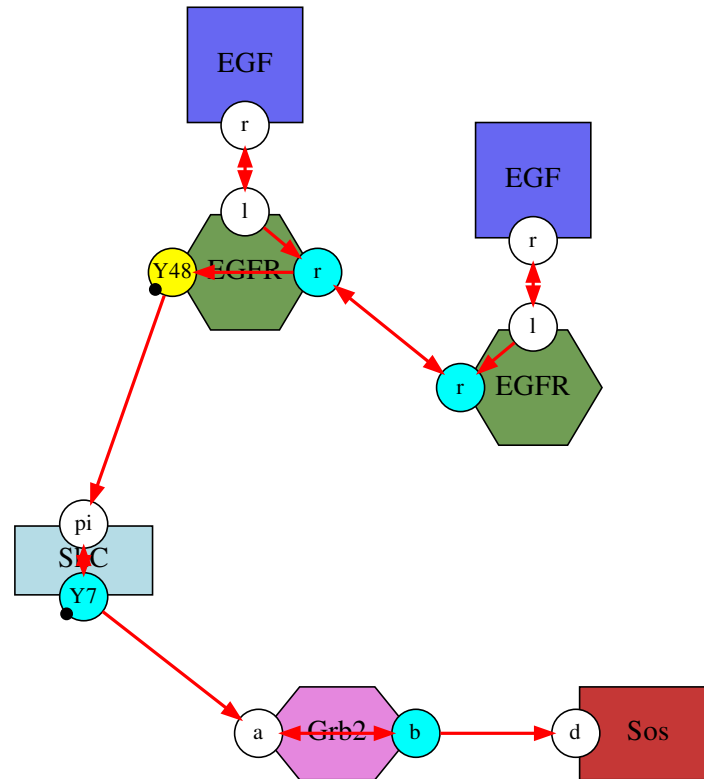

**Definition 2 (fragment)** A fragment is a prefragment that cannot be embedded in any bigger prefragment.

# Examples

## Which patterns are fragments?

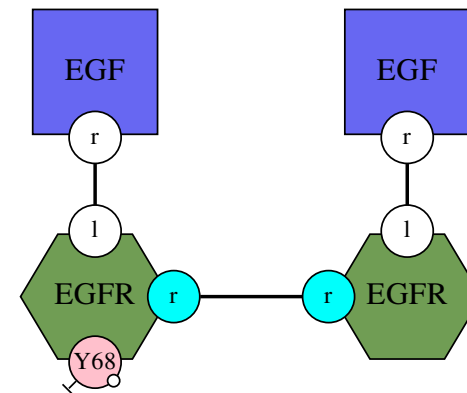
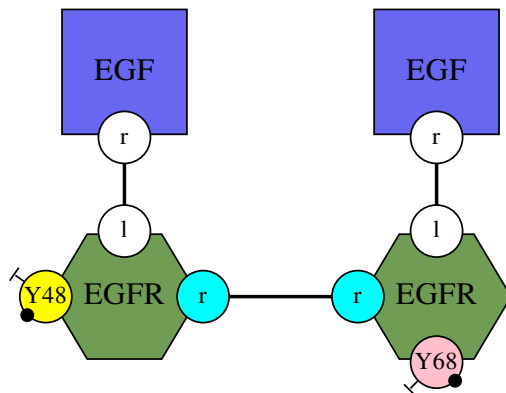
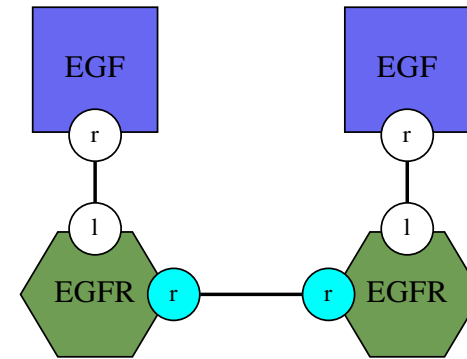
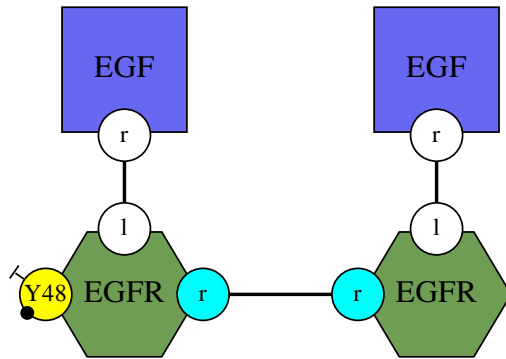

# Examples : annotated map

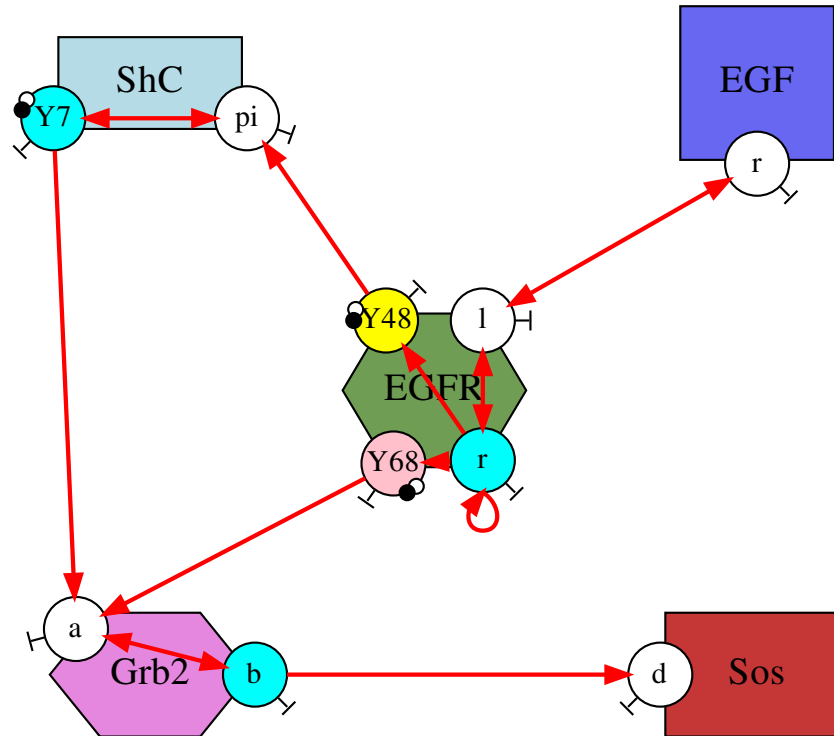
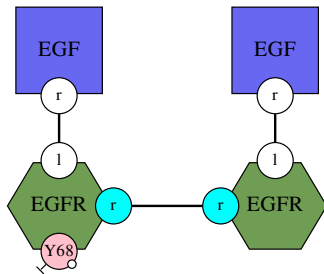
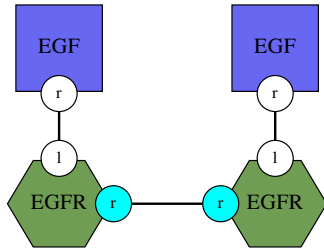
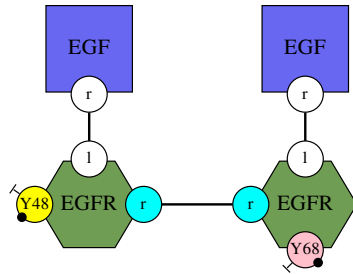
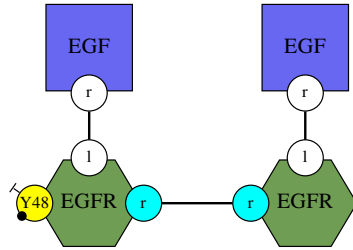



# Examples

## Which patterns are prefragments?

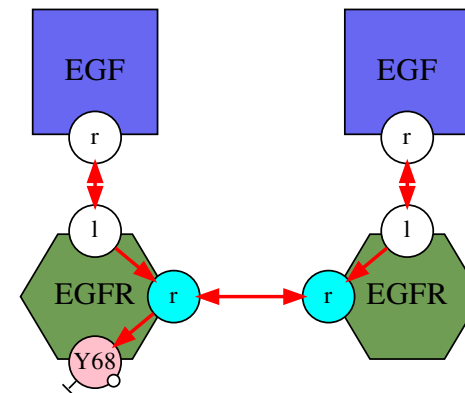
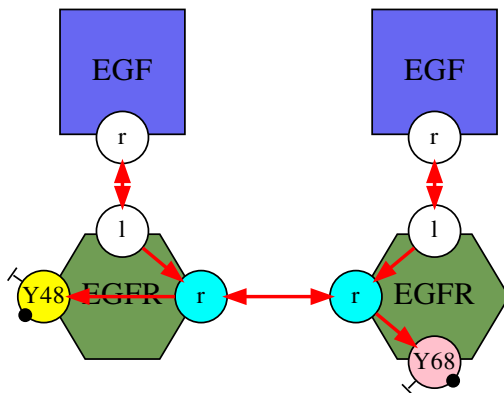
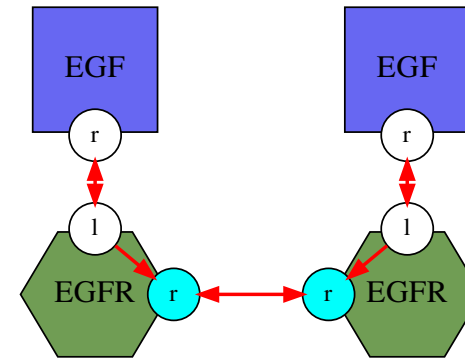
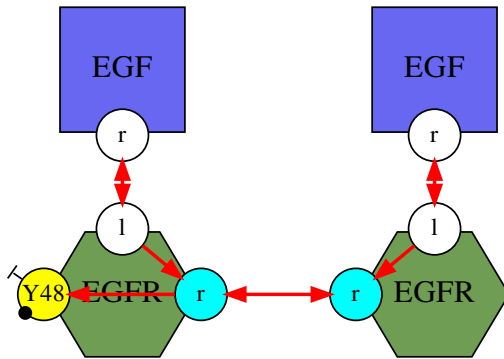

# Examples Prefragments

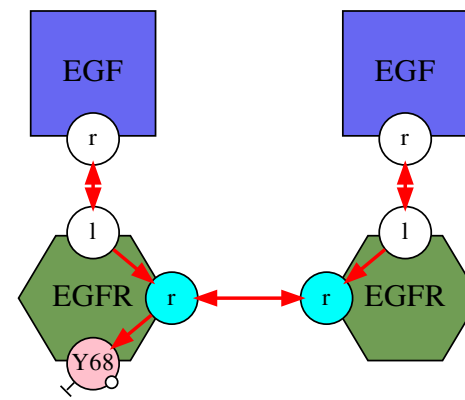
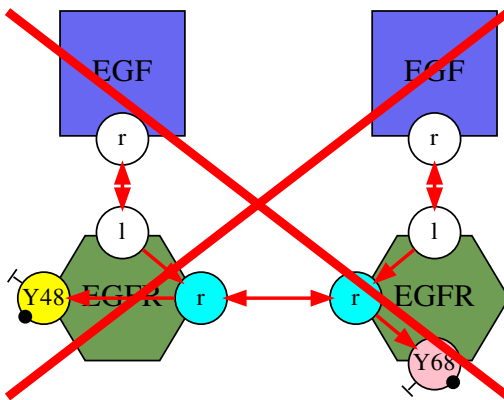
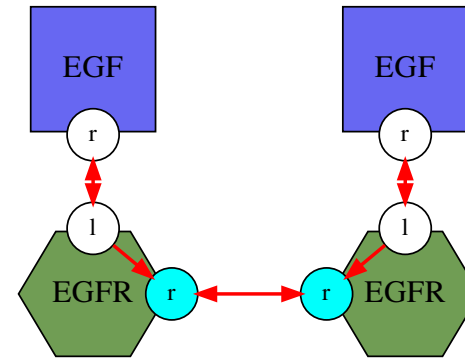
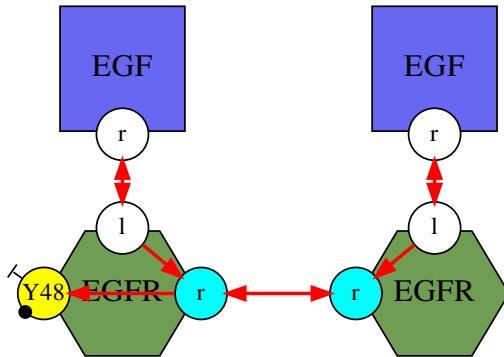

# Examples

## Which patterns are fragments?

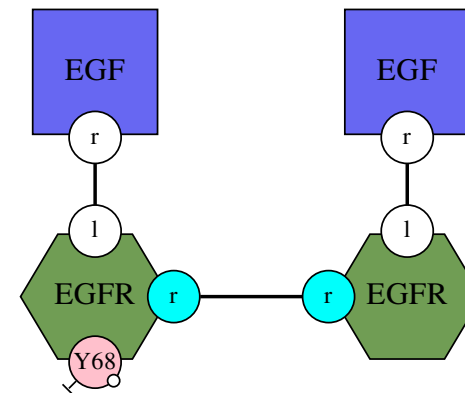
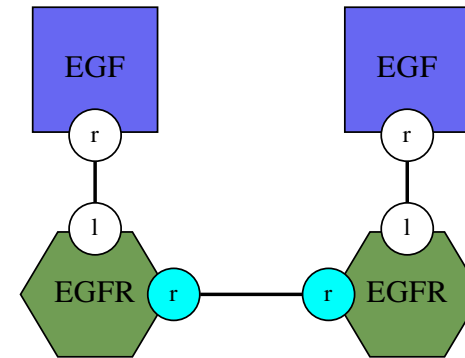
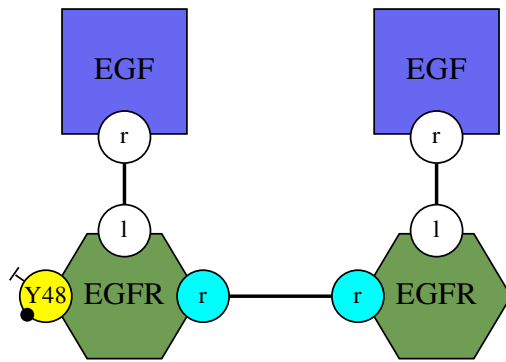

# Examples Fragments

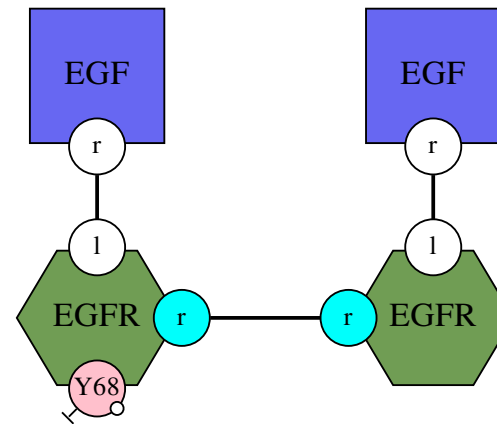
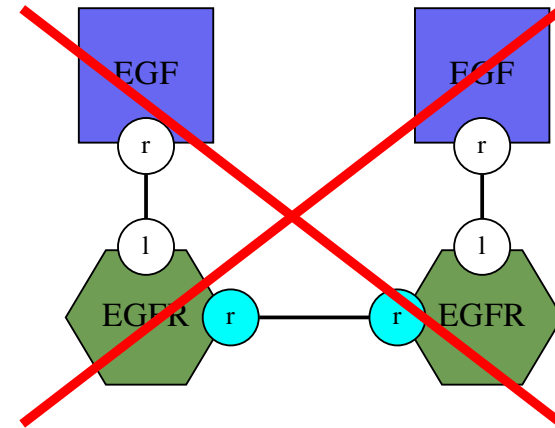
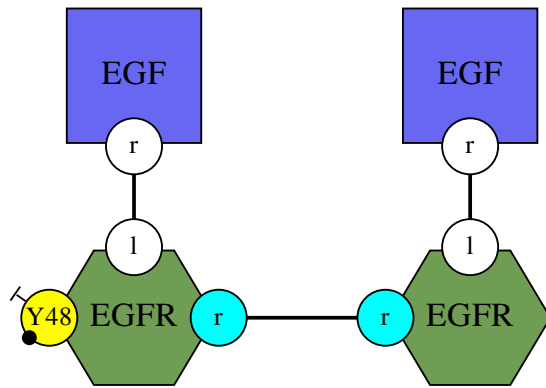



# Examples : fragments

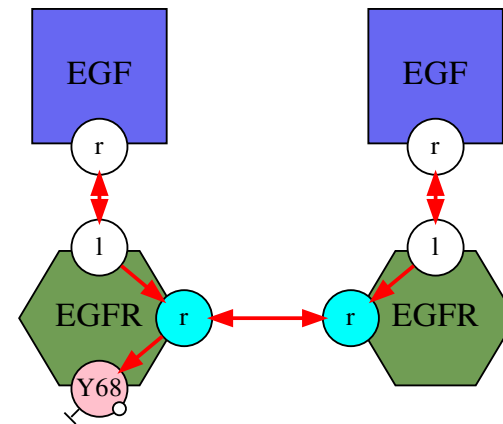
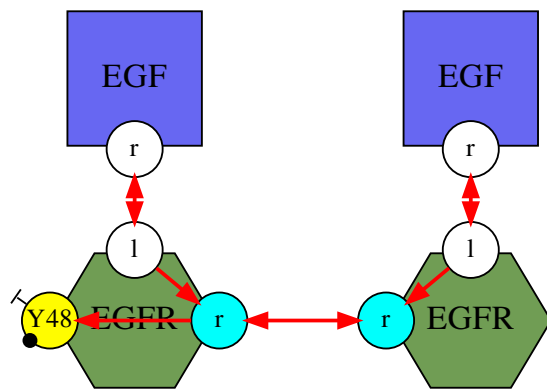

## Almost done...

We are left to express the consumption and the production (in concentration) of each fragment as expressions of the concentration of fragments.

Firstly, we notice that the concentration of each prefragment can be expressed as a linear combination of the concentration of the fragments.

# Fragments consumption

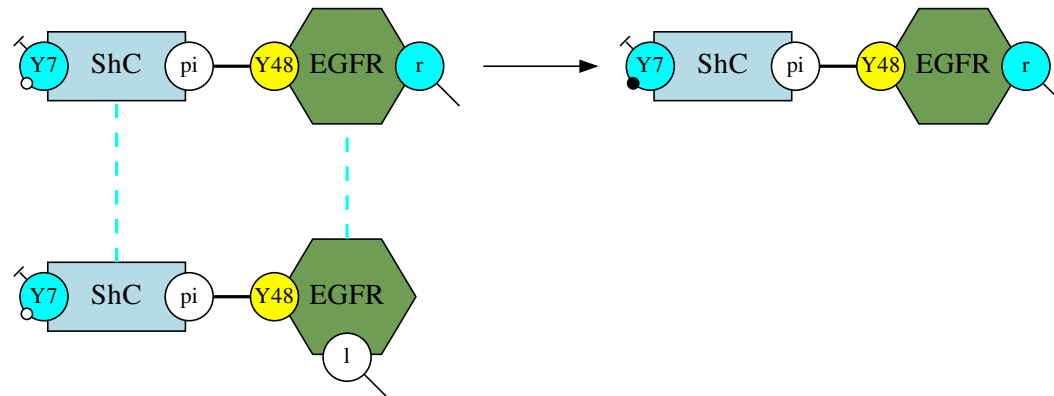

# Fragments consumption

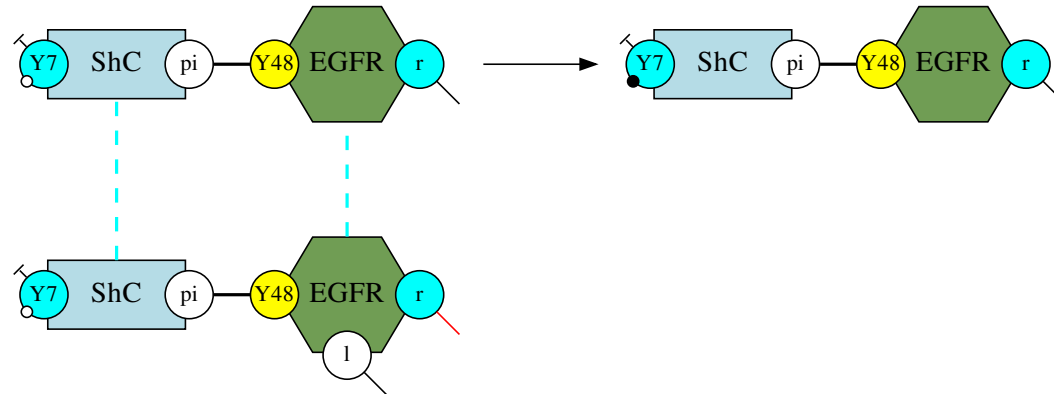

Whenever there is an overlap between a fragment and a connected component in the left hand side of a rule such that the common region contains a site that is modified by the rule, then the connected component embeds in the fragment.

# Fragments consumption

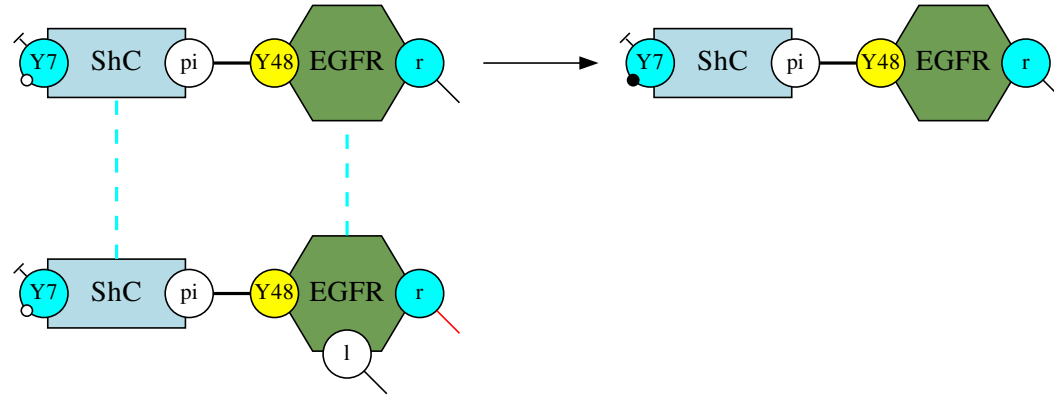

For each fragment  $F$ , for each rule:

$$r : C_1, \dots, C_n \rightarrow rhs \quad k$$

and for each occurrence of a connected component  $C_j$  that is modified by the rule, in a the fragment  $F$ , we have the following contribution:

$$\frac{d[F]}{dt} = \frac{k \cdot [F] \cdot \prod_{i \neq j} [C_i]}{\text{SYM}[C_1, \dots, C_n] \cdot \text{SYM}[F]}.$$

# Fragments production

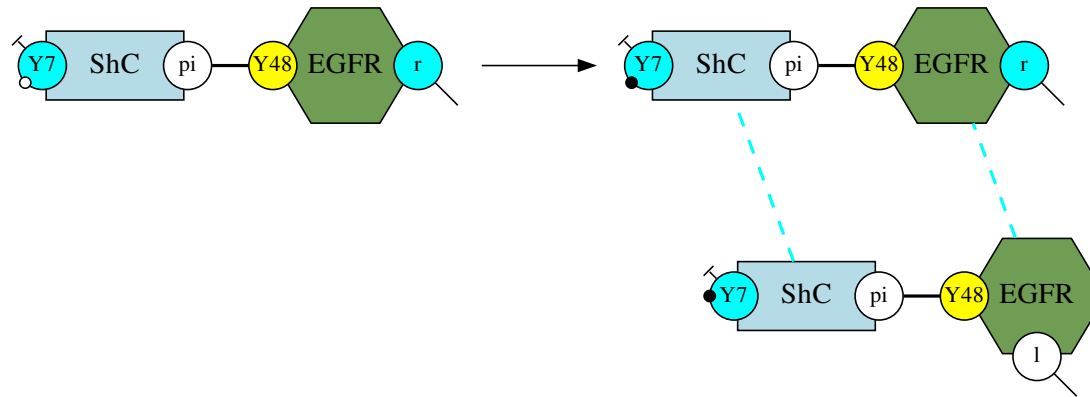

# Fragments production

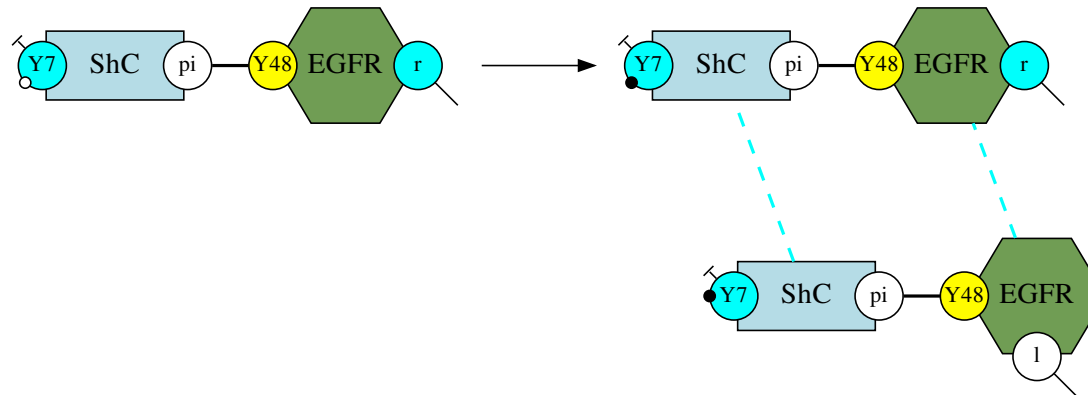

Whenever there is an overlap between a fragment and the right hand side of a rule, such that the common region contains a site that is modified by the rule...

# Fragments production

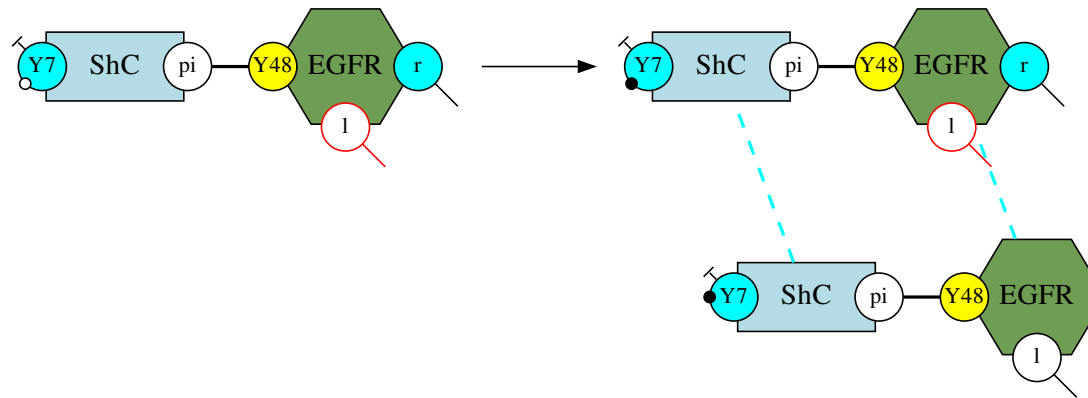

Whenever there is an overlap between a fragment and the right hand side of a rule such that the common region contains a site that is modified by the rule, each connected component in the left hand side of the refined rule, is a prefragment.



# Fragment production

For each overlap  $ch$  between a fragment and the right hand side of a rule, such that the common region contains a site that is modified by the rule:

$$r : C_1, \dots, C_m \rightarrow \text{righthand side} \quad k,$$

we have the following contribution:

$$\frac{d[F]}{dt} \stackrel{+}{=} \frac{k \cdot \prod_i [C'_i]}{\text{SYM}[C_1, \dots, C_m] \cdot \text{SYM}[F]}.$$

where  $C'_1, \dots, C'_n$  is the left hand side of the refined rule.

# On the menu today

1. Context and motivations
2. Case studies
3. Reduction of ordinary differential equations
4. Abstraction of the information flow
5. Model reduction
6. Conclusion

# Benchmark

Model	early EGF	EGF/Insulin	SFB
Number of molecular species	356	2899	$\sim 2.10^{19}$
Number of fragments (ODEs semantics)	38	208	$\sim 2.10^5$
Number of fragments (CTMC semantics)	356	618	$\sim 2.10^{19}$

# In short

# Abstraction of the information flow

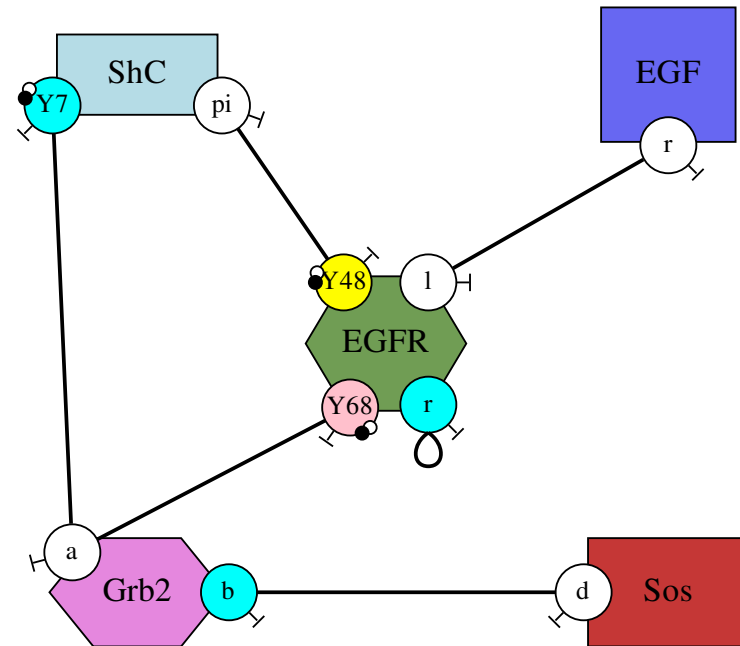
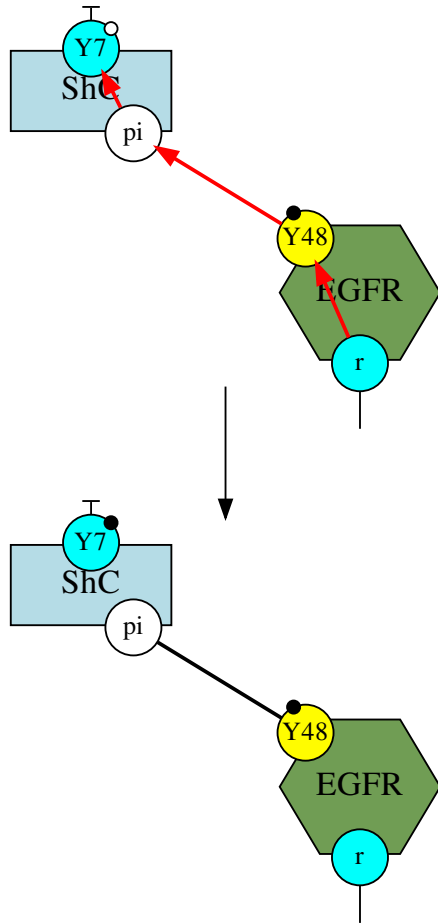

# Abstraction of the information flow

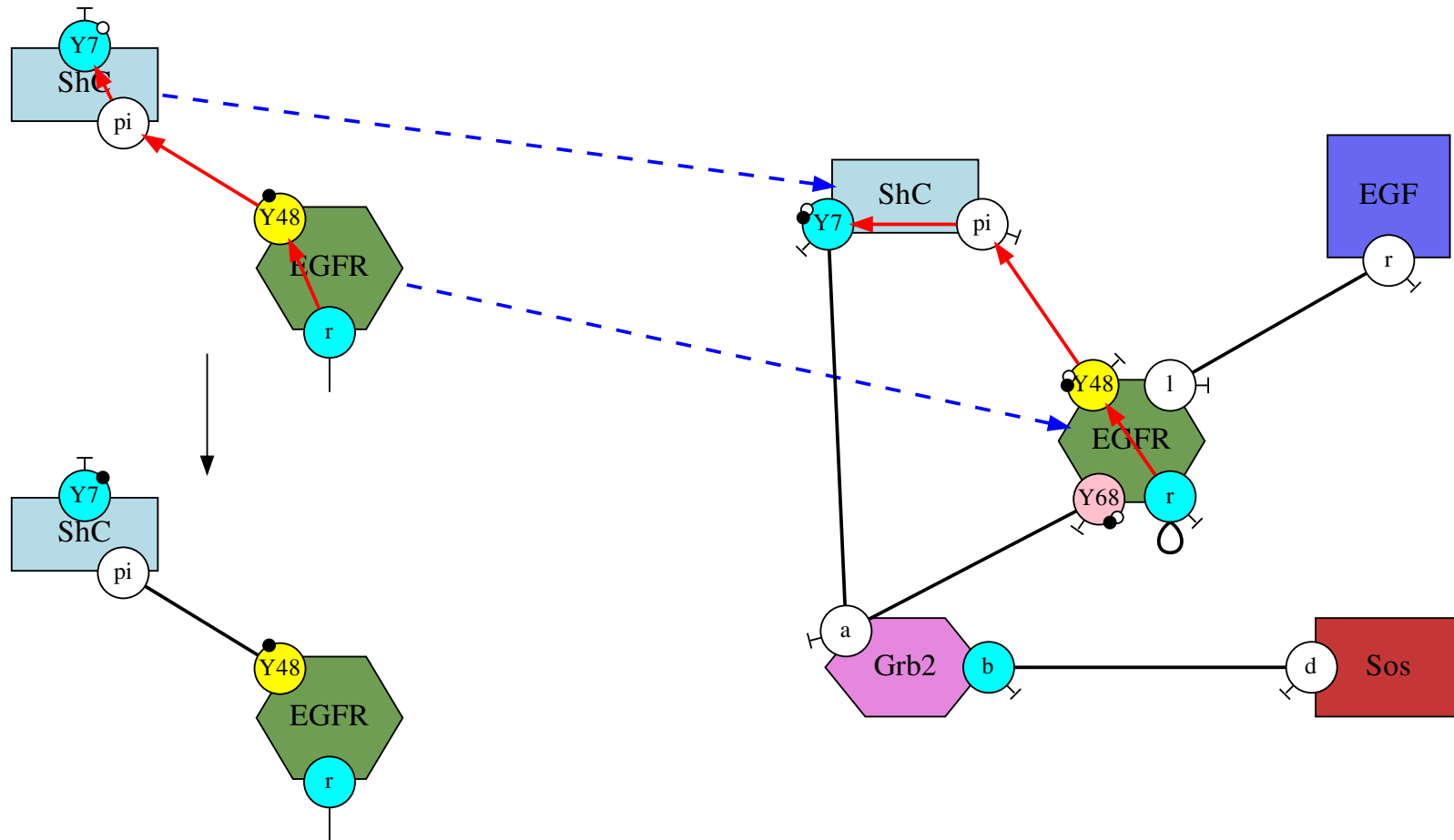



# Patterns of interest

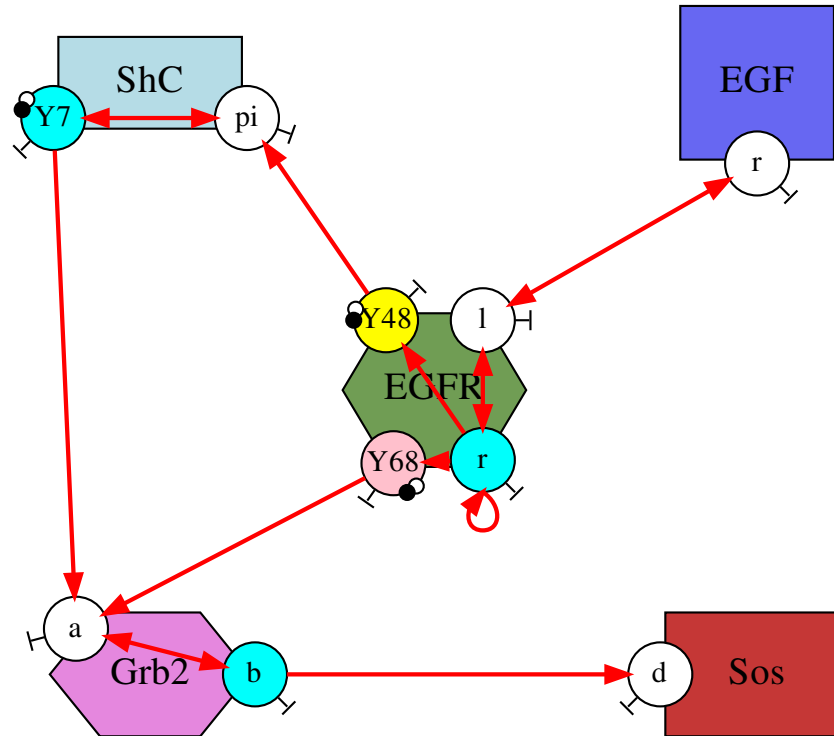
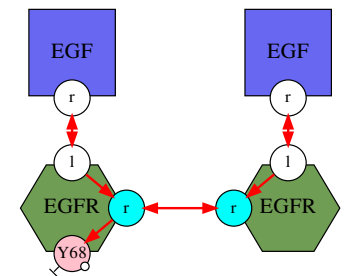
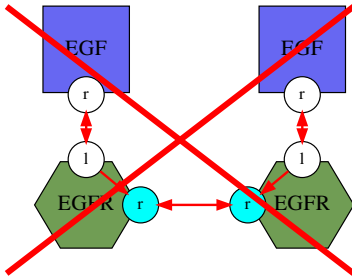
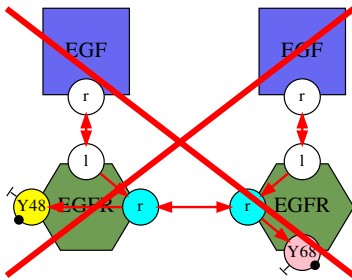
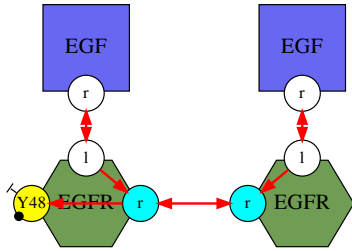



# Related topics and acknowledgements

- Model reduction (ODEs semantics)  
Vincent Danos, Walter Fontana, Russ Harmer, Jean Krivine
- Context-sensitive abstraction of information flow  
Ferdinanda Camporesi
- Model reduction (CTMC semantics)  
Tatjana Petrov, Heinz Koepl, Tom Henzinger
- Bisimulations metrics  
Norm Ferns.



“AbstractCell”  
(2009-2013)



“Big Mechanism” (2014-2017)  
“CwC” (2015-2018)



“TGF $\beta$ SysBio”  
(2015-2018)